



OWNERS AND SERVICE MANUAL
INNOVATIVE CONCEPTS IN ENTERTAINMENT INC.

TABLE OF CONTENTS

INTRODUCTION.....	PAGE 3
• GAME FEATURES	
• GAME PLAY	
INSTALLATION.....	PAGE 4
• BEFORE YOU BEGIN	
• INSTALLATION	
PROGRAMMING OPTIONS.....	PAGE 5 - 11
• INTRODUCTION	
• HOW TO ADJUST OPTIONS	
• USING THE PROGRAMMING OPTIONS	
MAINTENANCE.....	PAGE 12
QUICK TROUBLESHOOTING.....	PAGE 13 - 14
GAME REPAIR.....	PAGE 15 - 18
• OPERATIONAL BACKGROUND	
• TROUBLESHOOTING PHILOSOPHY	
• MECHANICAL REPAIR	
PARTS LISTINGS.....	PAGE 19
SCHEMATICS.....	PAGE 20 - 23
WIRING DIAGRAMS.....	PAGE 24 - 48

INTRODUCTION

GAME FEATURES

Thank you for purchasing the new Wheel A Win™ game from I.C.E. By combining the great play appeal of Cyclone™ and by adding the spinning wheel and great game sounds, we've taken the "Quick coin" game to a new level. You'll find this game to be a huge money earner now and for years to come.

Game cabinetry is stylish, yet bright and attractive using "glitter" decals to give it a glitzy look.



The game has been designed as a centerpiece game that will enhance the look of any location. Thick 16 gauge metal panels and marine grade water resistant plywood make the game extremely durable. The top of the cabinet is made of a special high impact styrene that is easy to maintain, and a thick acrylic dome that is extremely strong, and more scratch resistant than polycarbonate. Brilliant backlighting of the playfield completes the look.

Electronics and sounds are the state of the art in digital technology. Robust design ensures a long trouble free life for your game. The game is very flexible with its programming options to allow it to be tailored to most locations easily. (For special non-standard options, call our service department for details).

GAME PLAY

The object of the game is to spin the wheel in the hope that it stops at the big bonus values.

To spin the wheel the player must stop the rotating light in the "Spin Zone".



This will automatically spin the wheel for the player. The wheel spin is totally random. As is where the wheel stops.

INSTALLATION

BEFORE YOU BEGIN

WARNING: WHEN INSTALLING THIS GAME, A GROUNDED A.C. RECEPTACLE MUST BE USED. FAILURE TO DO SO COULD RESULT IN INJURY TO YOURSELF OR OTHERS. FAILURE TO USE A GROUNDED RECEPTACLE COULD ALSO CAUSE IMPROPER GAME OPERATION, OR DAMAGE TO THE ELECTRONICS

DO NOT DEFEAT OR REMOVE THE GROUNDING PRONG ON THE POWER CORD FOR THE SAME REASON AS GIVEN ABOVE. USING AN IMPROPERLY GROUNDED GAME COULD VOID YOUR WARRANTY.

HAVE A QUALIFIED ELECTRICIAN CHECK YOUR A.C. RECEPTACLE TO BE SURE THE GROUND IS FUNCTIONING PROPERLY.

INSTALLATION

The game comes ready to play with just a few simple things to keep in mind.

1. When installing the game, be sure you use a grounded A.C. outlet. If necessary, have it checked to be sure the ground is good.

THIS GAME IS DESIGNED TO DISSIPATE STATIC ELECTRICITY THROUGH THE GROUNDING PLANE OF THE GAME. IF THE A.C. GROUND DOES NOT WORK, THE GAME COULD DISCHARGE STATIC ELECTRICITY THROUGH THE GAME CIRCUITRY, WHICH COULD CAUSE DAMAGE.

Make sure the game is level after installation. It is necessary to make sure the game is level so the game will work properly.

TOOLS YOU WILL NEED

The game normally comes fully assembled and ready for use.

If however, you need to disassemble or reassemble the marquee to the game for any reason, all that is needed is a Phillips screwdriver, 7/64" Allen wrench and a 7/16" socket and ratchet.

Place the game into its final location and use the adjusting feet to level the game. This is important to do, to assure proper operation of the game.

CAUTION: CHECK THAT THE A.C. VOLTAGE RATING ON THE BACK OF THE GAME MATCHES THE A.C. VOLTAGE OF YOUR LOCATION.

THE POWER SUPPLY IS NOT VOLTAGE ADJUSTABLE.

TO OPERATE THE GAME AT VOLTAGES OTHER THAN THOSE IT WAS DESIGNED FOR, PLEASE CONTACT OUR SERVICE DEPARTMENT FOR VOLTAGE CONVERSION INFORMATION.

Plug the game into the A.C. outlet and turn power to the game on. The switch for the game is located on a power module inside the game.

It is now time to program your game.....

PROGRAMMING OPTIONS

INTRODUCTION

The Wheel A Win™ game is extremely flexible from a programming standpoint. This allows the customer to “fine tune” the game to his or her exact needs.

This section will describe in detail each of the programming options and how they work.

PLEASE READ THIS SECTION THOROUGHLY BEFORE CALLING OUR SERVICE DEPARTMENT. MOST QUESTIONS REGARDING SET-UP AND OPERATION WILL BE FULLY EXPLAINED HERE.

HOW TO USE THE PROGRAMMING OPTIONS

PROGRAMMING BUTTON – Use this button to enter and exit the programming mode. Press this button once to enter the mode, and once again to exit the mode.

SELECT BUTTON – Use this button to scroll through and “step” through the various options.

CHANGE BUTTON – Use this button to “change” the value of a particular option.

RESET BUTTON
CHANGE BUTTON
SELECT BUTTON
PROGRAMMING BUTTON



SETTING YOUR PAYOUT PERCENTAGE

The game has three basic adjustments to allow for percentaging the game properly. They are as follows:

LIGHT RING VALUES – These values can be changed through programming to allow for different ticket and game play values.



WHEEL JACKPOT VALUES – These can be changed through programming to allow for different ticket and game play values.



DIFFICULTY – This makes it easier or harder to hit the “spin zone” target. This will make the wheel spin less or more often. The wheel is set up with a difficulty of “6” from the factory. This allows the average player to spin the wheel about once every 20 times.

This setting is what we recommend you start with. It is important to keep it difficult enough to spin the wheel to keep the game interesting, but not so hard that it can't be done. It is important for bystanders to see that it is easy enough to do, so they will want to play as well.

CHANGING THIS SETTING IS THE EASIEST AND MOST EFFECTIVE WAY OF CHANGING YOUR PERCENTAGING.

WHEEL A WIN PROGRAMMING OPTIONS

#	Option	Min	Max	Def	Inc	Description
1	Coins Per Credit	0	10	1	1	0 = Free Play, Coins Input for Credit
2	Games Per Credit	1	10	1	1	Games Given Per Credit
3	Credit Discounting	0	10	0	1	Number of Consecutive Credit for Free Game
4	Volume	0	10	7	1	0 = Min 10 = Max
5	Attract Time	1	30	5	1	Value in Minutes
6	Attract Mode	0	3	3	1	0 = Off, 1 = Sound, 2 = Wheel, 3 = Both
7	Jackpot Tickets	0	50	0	1	Tickets paid before wheel spun
8	Zone 1 Value	0	20	3	1	Ticket payout for Zone
9	Zone 2 Value	0	20	3	1	Ticket payout for Zone
10	Zone 3 Value	0	20	4	1	Ticket payout for Zone
11	Zone 4 Value	0	20	4	1	Ticket payout for Zone
12	Zone 5 Value	0	20	5	1	Ticket payout for Zone
13	Zone 6 Value	0	20	5	1	Ticket payout for Zone
14	Zone 7 Value	0	20	6	1	Ticket payout for Zone
15	Zone 8 Value	0	20	6	1	Ticket payout for Zone
16	Zone 9 Value	0	20	7	1	Ticket payout for Zone
17	Zone 10 Value	0	20	7	1	Ticket payout for Zone
18	Zone 11 Value	0	20	7	1	Ticket payout for Zone
19	Zone 12 Value	0	20	7	1	Ticket payout for Zone
20	Zone 13 Value	0	20	6	1	Ticket payout for Zone
21	Zone 14 Value	0	20	6	1	Ticket payout for Zone
22	Zone 15 Value	0	20	5	1	Ticket payout for Zone
23	Zone 16 Value	0	20	5	1	Ticket payout for Zone
24	Zone 17 Value	0	20	4	1	Ticket payout for Zone
25	Zone 18 Value	0	20	4	1	Ticket payout for Zone
26	Zone 19 Value	0	20	3	1	Ticket payout for Zone
27	Zone 20 Value	0	20	3	1	Ticket payout for Zone
28	Jackpot 1 Value	0	100	300	10	Value of Non-Home Jackpot Spot
29	Jackpot 2 Value	0	100	500	10	Value of Home Jackpot Spot
30	Big Jackpot Lockup	0	1	0	1	1 = Game Lockup on Jackpot 1 or 2 ONLY
31	Wheel Difficulty	1	20	6	1	Spin Window Size
32	Winability	0	100	0	5	Game until Wheel Difficulty becomes Minimum
33	Counter Type	0	1	0	1	0 = Coins, 1 = Credits
34	Sound Loop	0	1	0	1	1 = Loop Sound and hold until Tickets Dispensed
35	Factory Reset	0	1	0	1	1 = Reset upon Exit

PROGRAMMING OPTIONS

FORMULATING YOUR PERCENTAGES

The game comes from the factory based on a average 25 cent play, and a 1 cent retail ticket value, with a payback of 40%.

AT THE END OF THIS SECTION ARE SOME BASIC EXAMPLES OF PAYOUT COMBINATIONS AND THE FORMULA FOR TRYING YOUR OWN COMBINATIONS. IF YOU ARE UNABLE TO MAKE ANY OF THESE COMBINATIONS WORK FOR YOU, PLEASE CONTACT OUR SERVICE DEPARTMENT.

COINS PER CREDIT (OPTION #1)

This option determines how many coins are needed to obtain 1 "credit". Setting a "0" puts the game into free play mode. The range for this option is 0-10. The default value for this option is "1".

GAMES PER CREDIT (OPTION #2)

This option determines how many games or turns the player gets per credit. This option is useful if you have a minimum coin value that is so high you need to give the customer multiple games to get good value. The range for this option is 1-10. The default value for this option is "1".

CREDIT DISCOUNTING (OPTION #3)

This determines the number of consecutive credits (without playing a game) given before dispensing a free game.

For example, if this option was set to "2", each time 2 coins IN A ROW were put in, a free game would be given.

The range for this option is 0-10. The default value for this option is "0".

VOLUME (OPTION #4)

This option determines the sound volume of the game. Setting a "0" turns the sound to minimum. Setting a "10" turns the sound to maximum. The default value for this option is "7"

ATTRACT TIME (OPTION #5)

This option determines the duration of time between attract modes in minutes. The range for this option is 1-30. The default value for this option is "2".

ATTRACT MODE TYPE (OPTION #6)

This option determines what type of attract mode (if any) is used. Setting a "0" turns the attract mode off. Setting a "1" makes sound only. Setting a "2" spins the wheel only. Setting a "3" gives both sound and the wheel spin. The default value for this option is "3"

JUST FOR SPINNING TICKETS (OPTION #7)

Enabling this option will give the player a predetermined amount of extra or "bonus" tickets before the wheel is spun. The tickets will begin to pay out as the wheel begins to spin. The range for this option is 0-50. Setting a "0" turns this option OFF. The default value of this option is "0".

PROGRAMMING OPTIONS

ZONE VALUES (OPTIONS #8-27)

The ring light values can be adjusted through programming and by changing the decals on the playfield itself.



This determines the ring light values for zones 1-20. Each zone can be set to pay out 0-20 tickets. The chart below will give you the default values for each zone, as well as translate the option number to the zone. Please see the chart above to realize the proper relationship between zone, option number, and position on the playfield. Example, Zone 10 is to the immediate right of the "spin zone" and is option #17.

OPTION#	ZONE#	DEFAULT
8	1	3
9	2	3
10	3	4
11	4	4
12	5	5
13	6	5
14	7	6
15	8	6
16	9	7
17	10	7
18	11	7
19	12	7
20	13	6
21	14	6
22	15	5
23	16	5
24	17	4
25	18	4
26	19	3
27	20	3

WHEEL JACKPOT VALUES

The jackpot values can be adjusted through programming and by changing the decals themselves. This helps to adjust for differing game play and ticket values

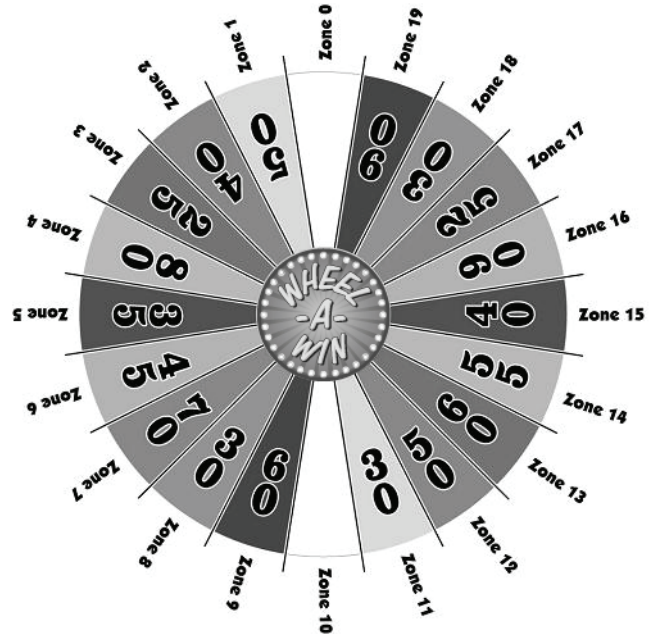

NON-HOME JACKPOT VALUE, ZONE 10 (OPTION #28)

This is the white jackpot wedge BELOW the words Wheel A Win on the center hub of the wheel. The numbers are removable and can be replaced with the other values supplied with the game.

The range for this option is 0-1000. The default value for this option is "300"

HOME JACKPOT VALUE ZONE 0 (OPTION #29)

This is the white jackpot wedge ABOVE the words Wheel A Win on the center hub of the wheel. The numbers are removable and can be replaced with the other values supplied with the game.

The range for this option is 0-1000. The default value for this option is "500"

PROGRAMMING OPTIONS

BIG JACKPOT LOCKUP (OPTION #30)

This option will allow the game to “Lock up” when either of the jackpot wedges are hit. This allows the location to save on tickets if the jackpot wedges are set to pay out a high amount. To clear the lock up, open the coin door and hit the “Ticket Reset” button on the cash box enclosure. The range for this option is 0-1. Setting a “1” turns this feature ON. The default value for this option is “0” (off).

WHEEL DIFFICULTY (OPTION #31)

this option determines how hard it is to stop the light in the “Spin Zone”. This adjusts the size of the “time window” to make it easier or harder. The numbers available represent MILLISECONDS (1/1000th of a second).

The range for this option is 1-20. The default value for this option is “6”.

When the game is set to “6”, average players will hit the spin zone approximately once every 20 times. This is where we feel the game works best, balancing difficulty with the excitement of being able to hit the target on a consistent basis.

CHANGE THIS SETTING TO RAISE OR LOWER THE PAYBACK PERCENTAGE.

In the event that the wheel difficulty needs to be changed, please use the chart below to give you a rough idea of how your changes will affect game play. These numbers will vary according to the age group and skill of your customers.

MILLISECONDS	1 IN XXXXXX HITS
1	1 IN 300
2	1 IN 120
3	1 IN 60
4	1 IN 45
5	1 IN 30
6	1 IN 20 (DEF)
7	1 IN 10
8	1 IN 5
9	EASY +

WINABILITY (OPTION #32)

If you wish to keep your percentages more accurate, or have some especially talented players that always win easily, you may want to use this option.

What win ability does is this. You set the “wheel difficulty” option to a number that is harder to win such as “3” (a one in 60 hit average). You then set this option to “20”. This means that after 20 games are played, the difficulty window will open to full open making it much easier to win. This way you’ll get a winner about every 20 games or so, but the more talented player would have to be much better to win. Since this still works based solely on skill, it remains fair and winnable for the advanced player, but will get easier to allow less skillful people to win as well.

The range for this option is 0-100. Setting a “0” turns this option OFF. The default value for this option is “0”.

COUNTER TYPE (OPTION #33)

This option determines how the money counters work in the game. Setting a “0” has the counters work so that each time a COIN is inserted the counter will increment 1. Setting a “1” has the counter work that each time a CREDIT (one OR MORE coins) is inserted and earned, the counter will increment by 1. The default setting for this option is “0” (Advances once for each coin inserted).

SOUND LOOP (OPTION #34)

This option will loop a money payout sound and lock up the game until all tickets have been dispensed IN THE EVENT OF A JACKPOT. This can add extra excitement to the game. The range for this option is 0-1. Setting a “1” turns this option on. The default value for this option is “0”, OFF.

PROGRAMMING OPTIONS

FACTORY RESET (OPTION #35)

This option is used to GLOBALLY RE-SET all of the software settings to the FACTORY DEFAULT. Setting a "1" will re-set all of the settings to their factory default as when you first received the game. The default value for this option is "0" (NO RE-SET).

IF YOU HAVE ANY QUESTIONS OR COMMENTS, PLEASE CONTACT OUR SERVICE DEPARTMENT.

I.C.E. SERVICE DEPARTMENT

716-759-0360

NORMAL BUSINESS HOURS ARE:

MONDAY – FRIDAY, 8:30 AM TO 6:00 PM EST

GAME SETTING EXAMPLES

The examples shown below are intended to act as a guide when setting up your game. Please be advised these are generalities and your game in all likelihood will need to be adjusted for your particular clientele.

25-cent play – 1-cent ticket
(spin zone) 7-6-6-5-5-4-4-3-3-2
Jackpot 500 – 300
6 MS Difficulty setting (average 1 in 20 spins)

80-cent play – 5-cent ticket
(spin zone) 5-4-3-2-2-2-2-2-1-1
Jackpot 500 – 300
6 MS Difficulty setting (average 1 in 20 spins)

50-cent play – 1-cent ticket
(spin zone) 10-10-9-9-8-8-7-7-7-7
Jackpot 900 – 900
7 MS Difficulty setting (average 1 in 15 spins)

5-cent play – 1-cent ticket
(spin zone) 2-1-0-0-0-0-0-0-0-0
Jackpot Bankrupt – Bankrupt
5 MS Difficulty setting (average 1 in 30 spins)

PAYOUT CALCULATION FORMULA

If you would like to try to figure out your own payout calculations, please use the formula on the next page.

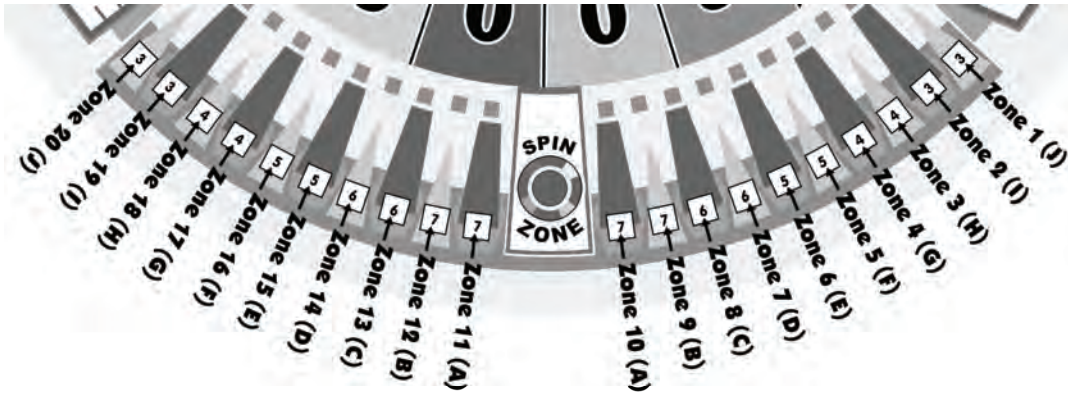

Total Wheel Value
= 905 + J1 + J2

$$\left[\left(\frac{[A+B+C+D] + \left[\frac{E+F+G+H+I+J}{6} \right]}{5} \right) (y) \right] + \left[\frac{905+J1+J2}{20} \right]$$

20

1. Assign Ticket Values to A-J, y (normally 19), and Jackpot 1 (J1; normally 300) and Jackpot 2 (J2; normally 500)
2. Add up values of A-D
3. Add up values of E-J and Divide by 6
4. Add the number you get in Step 2 to the number you get in Step 3
5. Take the number you get in Step 4 and divide it by 5
6. Take the number you get in Step 5 and multiply it by (y)
7. Add 905, J1 and J2 and divide that number by 20
8. Add the number you get from Step 6 and Step 7 together and divide that number by 20

***** This calculation assumes that the values on both sides of the spin zone are set the same. If you set the 2 sides different, run this calculation for both sides and average.**

MAINTENANCE

GENERAL MAINTENANCE

This game has been designed to be as trouble and maintenance free as possible.

With this in mind the only basics are to keep the game clean. Below are the main areas to take care of with specific directions.

TICKET DISPENSERS

The biggest problem ticket dispensers have is ticket dust blocking the optical detectors. It is a good idea to occasionally use compressed air to remove the dust from the dispensers.

DOME

The dome should be cleaned with a soapy water solution if covered with water based dirt such as food products. After cleaning with soapy water, polish with a commercial plastic polish or a spray furniture polish. These have lubricating oils that condition the plastic and keep it shiny and clear looking. Never use regular glass cleaners as the ammonia in them actually damages the plastic and dulls it.

Any deep scratches can be reduced or eliminated with a scratch removing polish and buffing wheel.

CABINET

The cabinet plastic and decals can be cleaned with soapy water or spray furniture polish. DO NOT use any alcohol or petroleum based cleaners as they could damage the plastic or printed parts.

COIN MECHANISMS

The coin mechanisms should be cleaned periodically, as they will accumulate dirt which will cause the coins to stick.

Remove the coin mech and clean them in a dish detergent solution and a stiff brush. Dry thoroughly and re-install.

QUICK TROUBLESHOOTING

GAME WILL NOT TAKE OR ADD MONEY CORRECTLY

- Micro switch not working or returning properly. Check and repair or replace as necessary.
- Bad Harnessing or connector. Check w/ohm meter and repair as necessary.
- Game programming set incorrectly. Check programming option and re-program if necessary.
- Bad Main P.C. Board. Check and repair or replace as necessary.

STOP BUTTON WILL NOT FLASH WHEN GAME HAS CREDITS, OR WORK WHEN PUSHED

- Micro switch not working properly. Test and replace as necessary.
- Micro switch popped out of housing. Snap back into housing.
- Burned out light bulb. Replace light bulb.
- Bad harnessing or connector. Check w/ohm meter and repair as necessary.
- Bad Main P.C. Board. Check and repair or replace as necessary.

GAME HAS NO SOUND

- Bad speaker. Check w/ohm meter for 4 or 8-ohm load. If not within this range, replace.
- Volume level set incorrectly. Check volume level in programming, and adjust if necessary.
- Bad Harnessing or connector. Check w/ohm meter and repair as necessary.
- Bad Main P.C. Board. Check and repair or replace as necessary

TICKET DISPENSER DOES NOT WORK OR WORKS IMPROPERLY

- Bad ticket dispenser. Repair or replace as necessary.
- Bad harnessing or connector. Check w/ohm meter and repair as necessary.
- Bad Main P.C. Board. Check and repair or replace as necessary.
- Game out of tickets. Add tickets
- Optical sensor on ticket dispenser dirty. Remove paper fuzz and debris with a soft brush.

NO FLORESCENT LIGHTING

- Bulb burned out. Replace bulb.
- Electronic ballast bad. Replace ballast.
- Harness bad or harness unplugged. Check w/ohm meter and plug in, repair or replace as necessary.
- No A.C. power to the game or Main fuse bad. Check fuse and A.C. power.

ALARM SOUND DOES NOT WORK OR FALSE TRIGGERS (OPTIONAL)

- Bad Main P.C. Board. Check and repair or replace as necessary
- Bad Harnessing. Check w/ohm meter and repair or replace as necessary.
- Alarm Plum bob set up improperly. Check for proper plum bob clearance and adjust as necessary.
- Game not level. Level game to be sure plum bob is operating correctly.
- Game unplugged. Plug game back in and test for proper operation.

WHEEL WILL NOT SPIN OR SPINS SLOWLY

- Bad Motor. Check or replace as necessary
- Bad harnessing. Check and repair as necessary
- Bad motor cooling fan causing overheating of motor. Replace fan.
- Clicker solenoid not disengaging properly. Check and replace solenoid if necessary.
- Clicker return spring. Check and replace spring if necessary.

QUICK TROUBLESHOOTING

LIGHT RING DOES NOT LIGHT

- Bad Main P.C. Board. Fix or replace main board.
- Bad light ring board. Find problem board and replace or repair as necessary.
- Bad light ring board harnessing. Repair as necessary.
- Blown fuse on Main P.C. Board. Replace fuse. Check for problems.

MARQUEE DOES NOT LIGHT

- Burned out or bad bulb. Replace bulb.
- Bad or disconnected harnessing. Replace or connect harnessing.

CREDITS OR TICKETS OWED DISPLAYS DON'T WORK PROPERLY

- Bad Display P.C. Board. Repair or replace Display board
- Bad Main P.C. Board. Repair or replace Main board.
- Bad display harnessing. Repair as necessary.

CAN'T ENTER OR EXIT PROGRAMMING OR OTHER ADJUSTMENT MODES

- Bad programming or adjustment buttons. Replace buttons. Check harnessing.
- Harnessing fell off back of button. Re-attach harnessing.
- Bad Main P.C. Board. Repair or replace Main board.

GAME REPAIR

WARNING: ALWAYS REMOVE POWER TO THE GAME BEFORE ATTEMPTING ANY SERVICE, UNLESS NEEDED FOR SPECIFIC TESTING.

FAILURE TO OBSERVE THIS PRECAUTION COULD RESULT IN SERIOUS INJURY TO YOURSELF OR OTHERS.

OPERATIONAL BACKGROUND

The Wheel A Win™ game has been manufactured with modular design in mind. Almost everything in the game can be EASILY removed for servicing. This makes it much easier for the repairman as he /she can work in a quieter less distracting environment away from the Game Room floor. The game relies on 1 brushed DC for the mechanical spinning of the wheel. This motor can be accessed easily for service.

Coin and low ticket sensing are done with conventional micro switches. In all areas of critical importance, optical sensors were developed specifically, and optimized for their particular application.

All P.C. Boards are made of premium quality board material and use time proven components to assure you of the most reliable designs possible.

We have put forth our best efforts and tested this game extensively to assure the best possible performance under the widest variety of operating conditions. We are ALWAYS however interested in our customers input for product improvement. If you have any questions or comments please feel free to contact our service department.

I.C.E. SERVICE DEPARTMENT

716-759-0360

NORMAL BUSINESS HOURS ARE:

MONDAY – FRIDAY, 8:30 AM TO 6:00 PM EST

TROUBLESHOOTING PHILOSOPHY

To find problems with the game, always first check what should be obvious. See that the game is plugged in, and that all of the fuses on the game are good. This includes the fuse that is located INSIDE the power module.

Next, check to see that all of the connectors are firmly seated and that none of the wires have been pulled out of them.

When trying to find out if specific components are bad or not, try swapping them with components from another player station to see if the problem moves with the component, or stays where it was. This will help you to know if you have a problem with a specific component, or maybe a problem with either the wiring or the Main P.C. Board.

Use extreme caution when using probes or voltmeters if the game is powered up. If doing continuity checks, it is important to disconnect the harnessing at both ends, as attached they may yield erroneous results.

If a P.C. Board is suspected as the cause of a problem, check to see that all of the components on the board are firmly attached. Pay special attention to any socketed devices.

If light bulbs are suspected, swap them with one that is known to work to narrow the problem down to either a bulb or P.C. Board.

GAME REPAIR

REPLACEMENT & REPAIR

LIGHT RING SERVICING

Service the light ring as follows:

1. Remove the Allen bolts that hold the cover on to the cabinet.



2. Lift the cover up and remove the dome. (See dome replacement instructions)
3. Remove the 2 wheel clickers by unscrewing them.



4. Remove the Light Ring graphics by lifting the ring up.



5. Remove the plastic spacers that hold the board in place.
6. Remove the connector to the board.

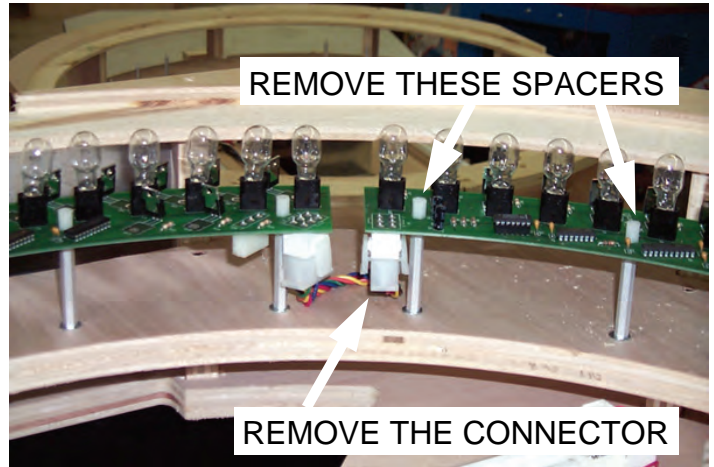

7. Assemble in the reverse order.

MOTOR SERVICING / REPLACEMENT

Service the motor as follows:

1. Remove the Allen bolts that hold the cover on to the cabinet.



GAME REPAIR

2. Lift the cover up and remove the dome. (See dome replacement instructions)
3. Remove the wheel by unscrewing the 3 screws that hold it in place.



4. Remove the motor by unscrewing the screws that hold it in place.

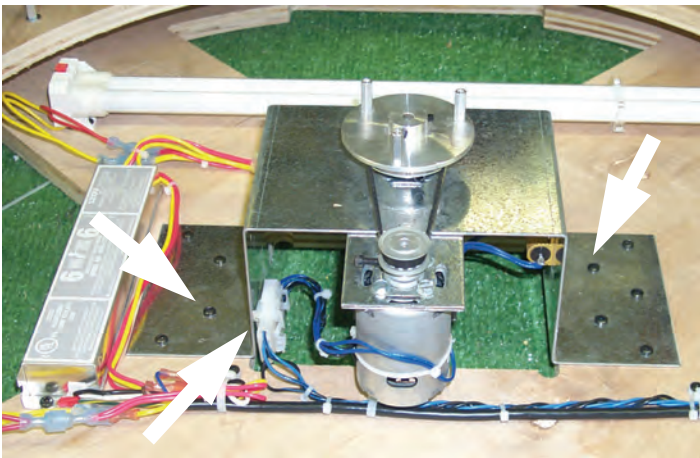

5. Disconnect the plug on the motor from the motor harness.
6. Assemble in reverse order.

MARQUEE BULB SERVICE

To replace the PL-L fluorescent light bulb, follow the directions below.

1. Remove the 4 Allen head screws from the front of the Phillips head screws that hold the Marquee Cover in place.



2. Remove the clip that attaches the bulb. Remove the bulb from its socket by pressing the "red" button and lifting the light bulb out.

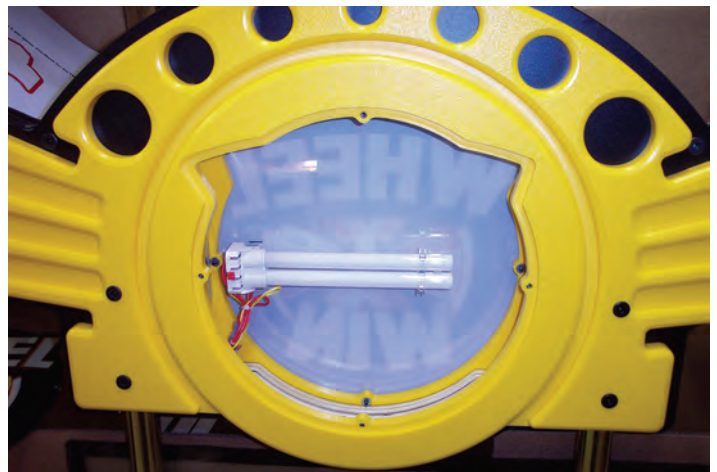

3. Replace the bulb and reattach the Marquee Cover.

GAME REPAIR

CREDITS / TICKETS OWED P.C. BOARD SERVICE

1. Remove the Allen bolts that hold the cover on to the cabinet.



2. Lift the cover up to access the Display P.C. Boards.

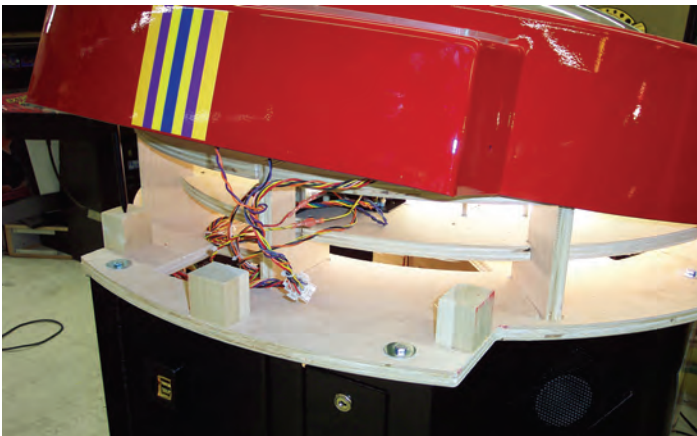

3. Unscrew and remove the boards for service.

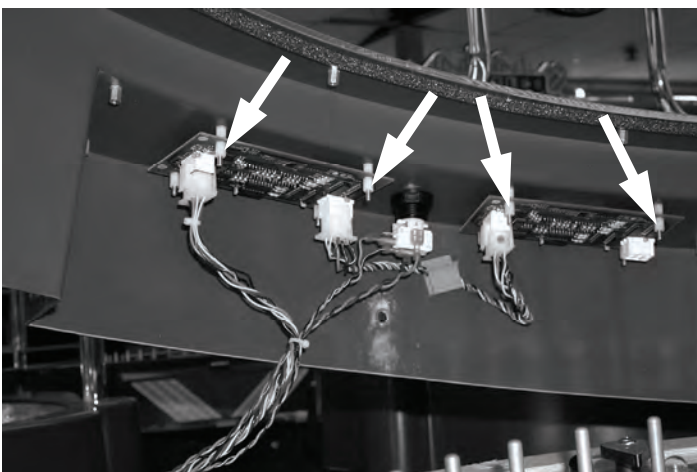

4. Reassemble in reverse order.

DOMES REPLACEMENT

1. Remove the Allen head bolts that hold the cover to the cabinet.



2. Lift up the cover and remove the Dome.



3. Set the new dome onto the playfield centered evenly in the game.
4. Lower the cover and bolt into place.

IF YOU HAVE ANY QUESTIONS OR COMMENTS, PLEASE CONTACT OUR SERVICE DEPARTMENT AT:

716-759-0360

MON. THRU FRI. 8:30AM-6:00PM EST

PARTS LISTINGS

Parts denoted with * indicate available as part of a specially discounted spares kit.

ELECTRONIC / ELECTRICAL

MECHANICAL PARTS

211	Low Ticket Micro Switch
BW250X	PLL Bulb Socket Assembly
FP1004	Leg Leveler Mounting Bracket
HR1019	Leveler Foot
1024	Ticket Bin
1026	Bracket, Low Ticket Switch Mounting
WF1050	Clicker Pole, Teflon Coated
WF1051	Wheel Hub
WF1052	Wheel Pin, 1"
WF1053	Wheel Pin, 1.5"
WF1054	Wheel Pin, 2"
WF1055	Wheel Pin, Non Extension
WF1056	Flag, Opto Beam Breaker
WF1060*	Clicker Spring
CG1068	Bushing, Bronze Oil Impregnated
HR2005	Large Round White Push Button
AR2007	Speaker, 6" x 9"
BW2017	PLL Bulb Retaining Clip
BW2018	PLL Bulb Support
2027	Fan, DC 12 Volt
CC2027	Power Cord, 20ft.
WF2007X	Power Module
2364G	Fan Guard
WF3004*	Clicker (Pointer)
WW3001	Control Panel (Red)
WW3002	Marquee Housing
WF3024X	Dome Assembly, with tape
HH5005	Ticket Dispenser
5101X	Mech Holder Assembly
WF6001X*	Parts Package
6321	3/8" E-Clip
8312*	Bulb, PL-L 40W/41/RS/IS Fluorescent
WF9010	Cover, Clicker Sensor (Black Card)
WF1018	Bracket, Clicker
WF1018AX	Assembly, Player Clicker 1

WF2002X	Transformer
2008*	Solenoid, Spring Tensioner
WF2008X*	Motor Assembly
WF2034X	Main P.C. Board
WF2038X*	Clicker Position P.C. Board., Large
WF2039X*	Clicker Position P.C. Board, Small
WF2040X*	Wheel Position P.C. Board, Outer
WF2041X*	Wheel Position P.C. Board, Inner
2110	TIP 122 Transistor
2117	IC, 74hc14
2305	IC, 74hc273
CC2032X*	Tickets Owed Display P.C. Board
CC2035X*	Light Ring Board (Banana Board)
CS8449X	Workhorse 6 Ballast, (WH3-120-L)
2295	Fuse, MDQ6 (6 Amp Slo Blo)
2315	Fuse, MDQ3 (3 Amp Slo Blo)
HH2048F	Fuse, MDQ4 (4 Amp Slo Blo)

DECALS AND GRAPHICS

WW7001	Side Panel Decal
WW7002	Center Wheel (sold w / WW7013)
WW7003	Control Panel - Front Decal
WW7004	Decal - Button
WF7005	Instruction Plate Decal
WF7006	Ticket Arrow Decal
WW7012	Control Panel
WW7013	Outer Ring (sold w / WW7002)
WW7027	Marquee Panel
WW9001	Service Manual

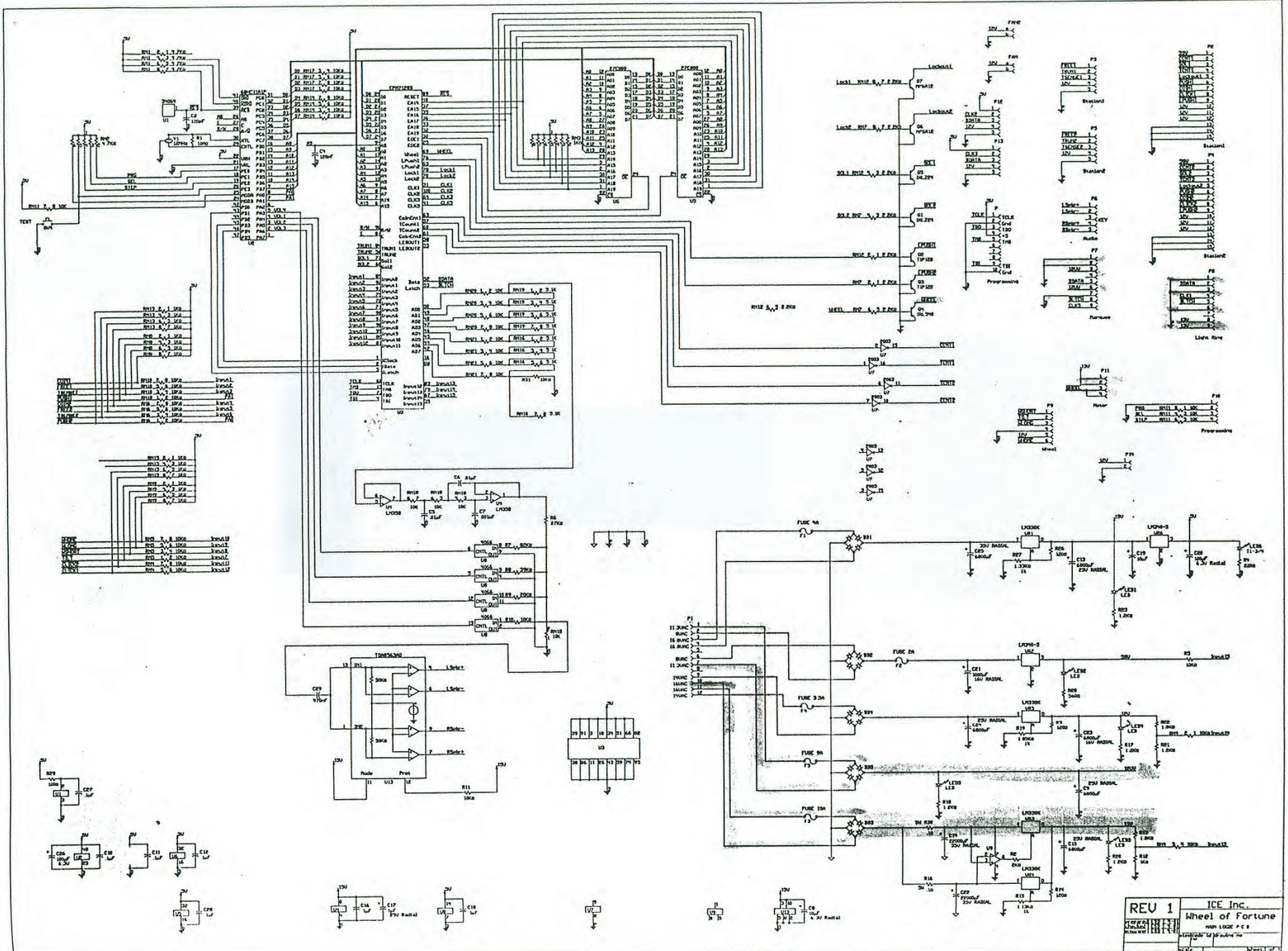

REV 1 ICE Inc.
 Wheel of Fortune
 1000 LOC. P.C.S.
 1000 LOC. P.C.S.
 1000 LOC. P.C.S.

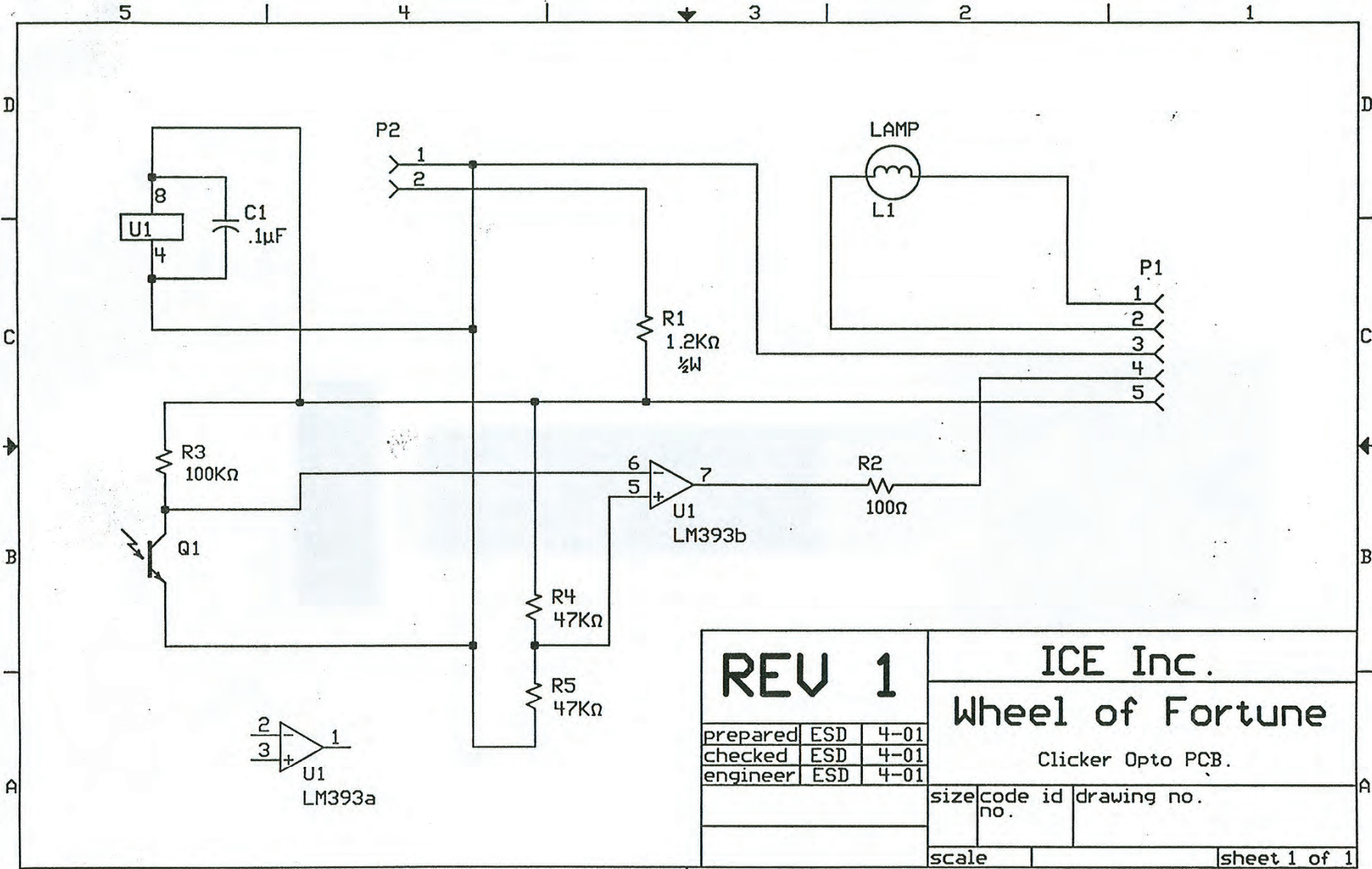

REV 1			ICE Inc.		
			Wheel of Fortune		
			Clicker Opto PCB.		
prepared	ESD	4-01	size	code id	drawing no.
checked	ESD	4-01	no.		
engineer	ESD	4-01	scale		sheet 1 of 1

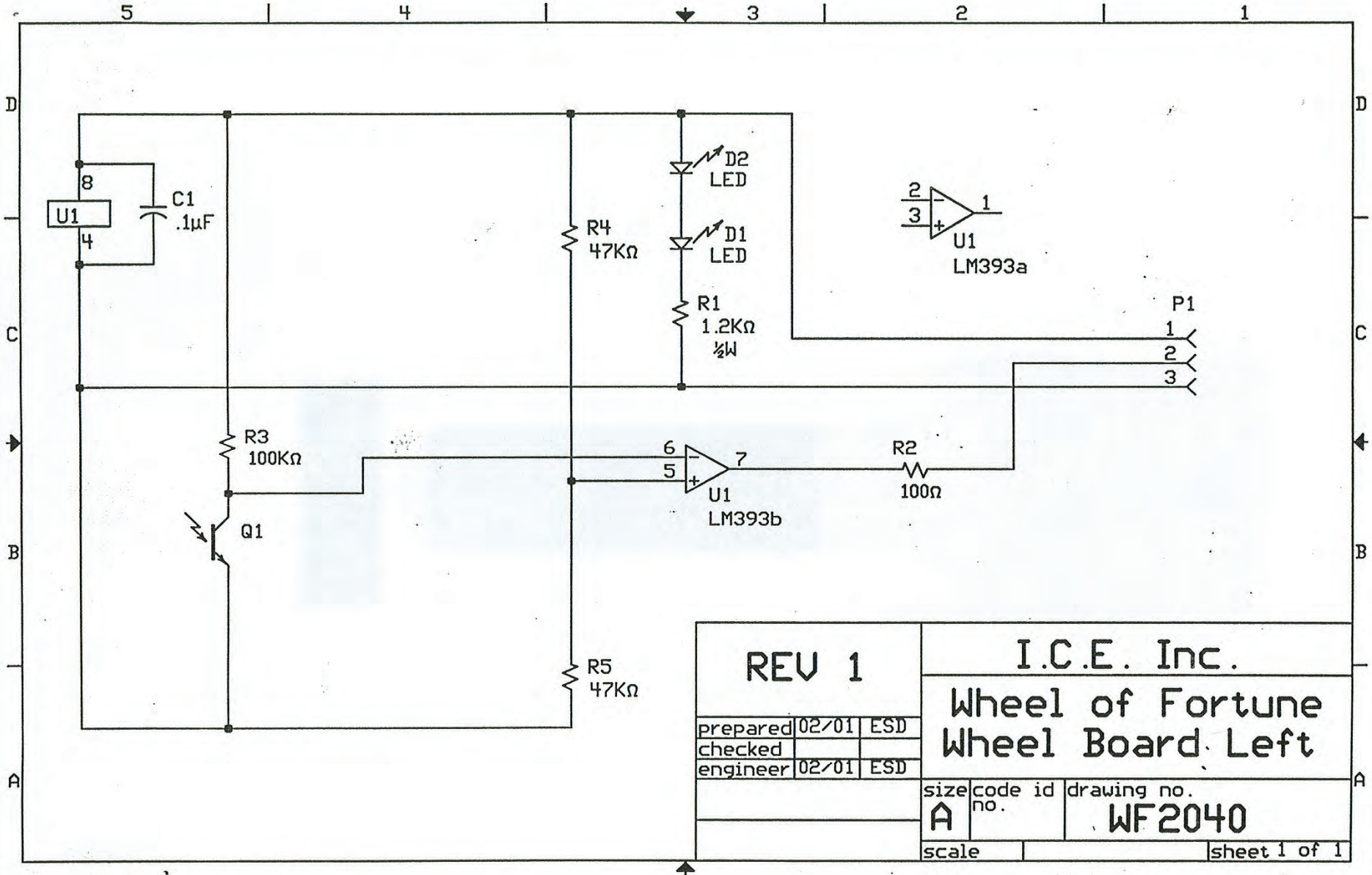

REV 1

I.C.E. Inc.

Wheel of Fortune
Wheel Board Left

prepared	02/01	ESD
checked		
engineer	02/01	ESD

size	code id	drawing no.
A	no.	WF2040
scale	sheet 1 of 1	

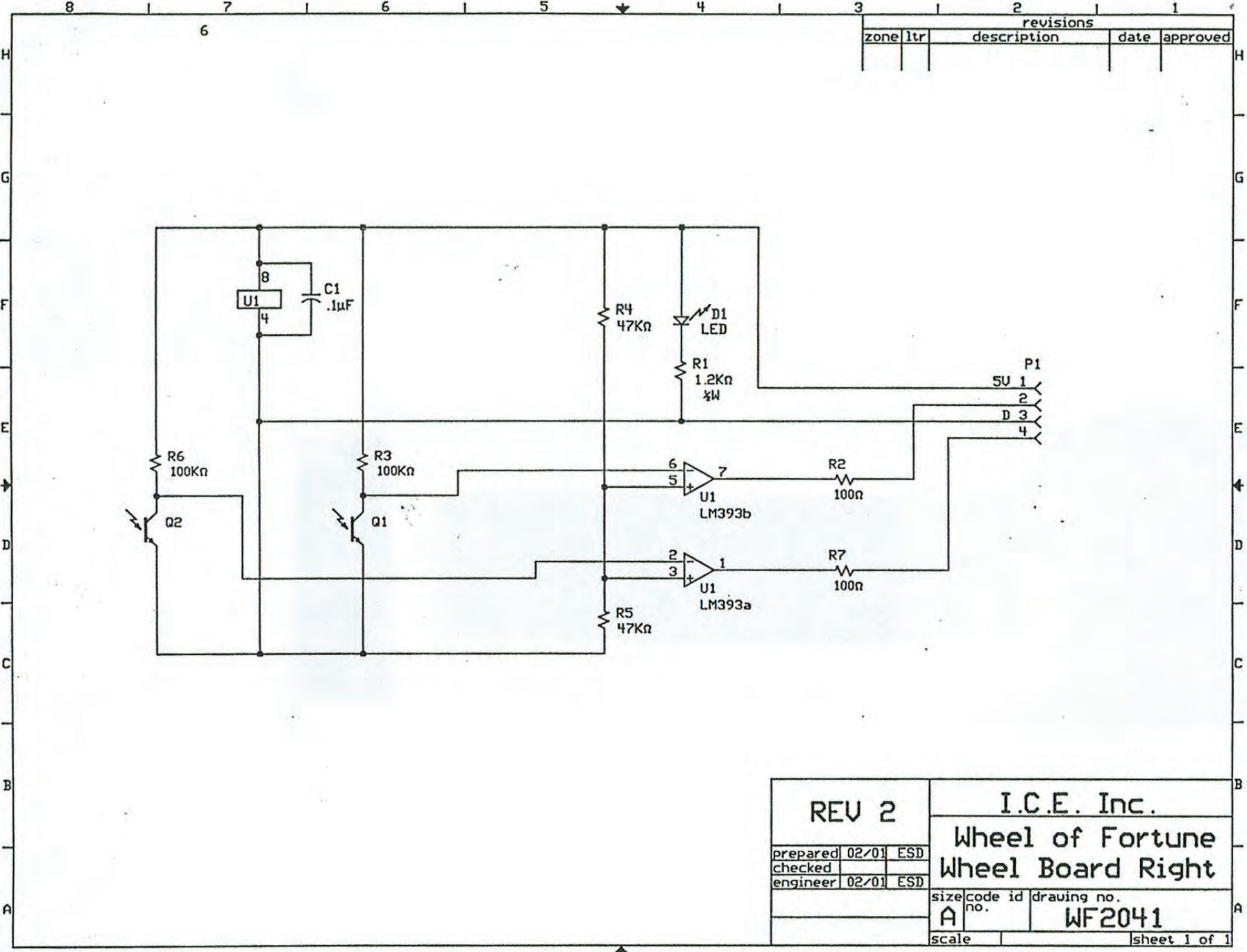

revisions				
zone	ltr	description	date	approved

REV 2			I.C.E. Inc.		
prepared 02/01 ESD			Wheel of Fortune		
checked			Wheel Board Right		
engineer 02/01 ESD			size code id drawing no.		
			A no. WF2041		
			scale sheet 1 of 1		

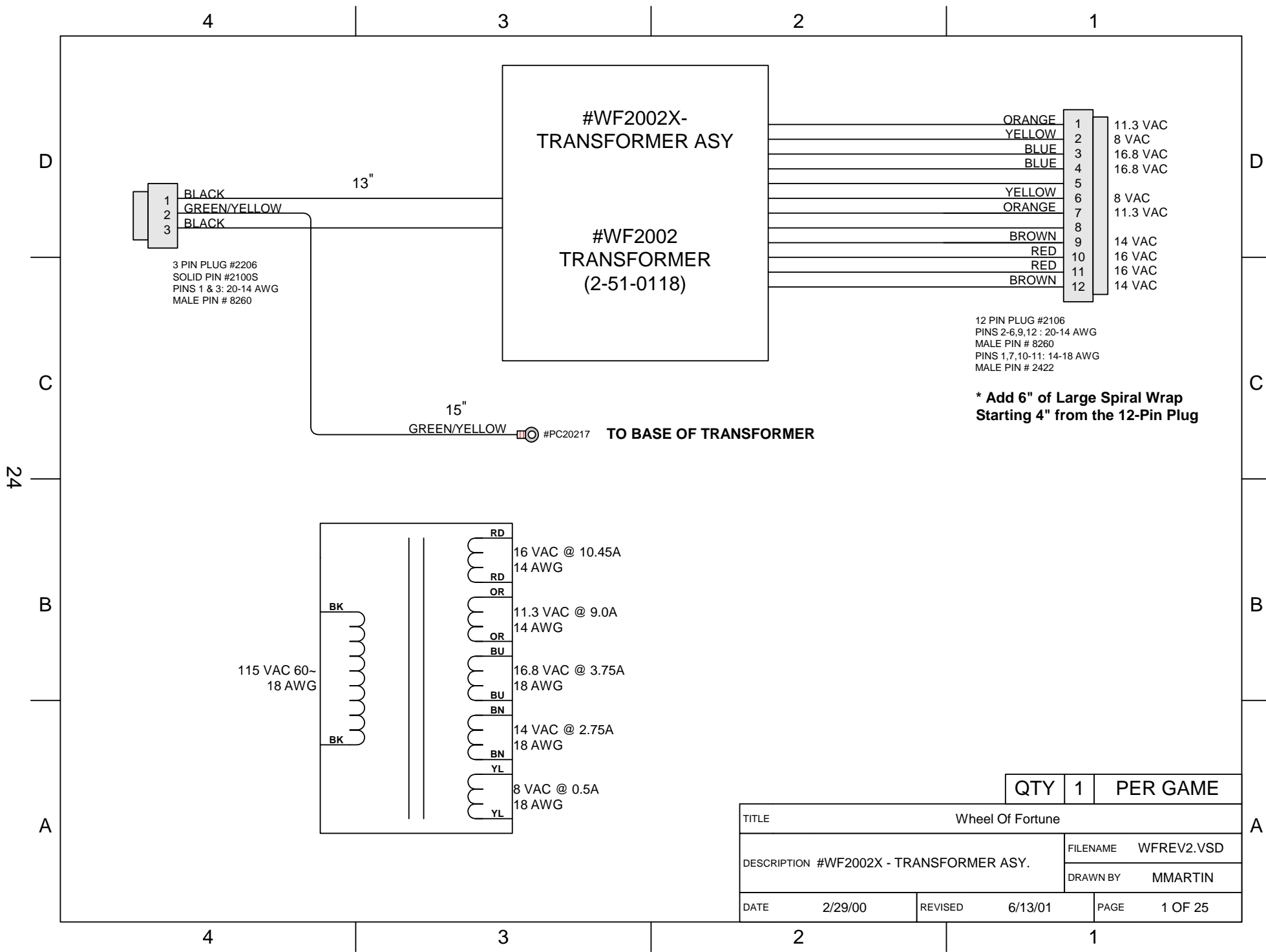

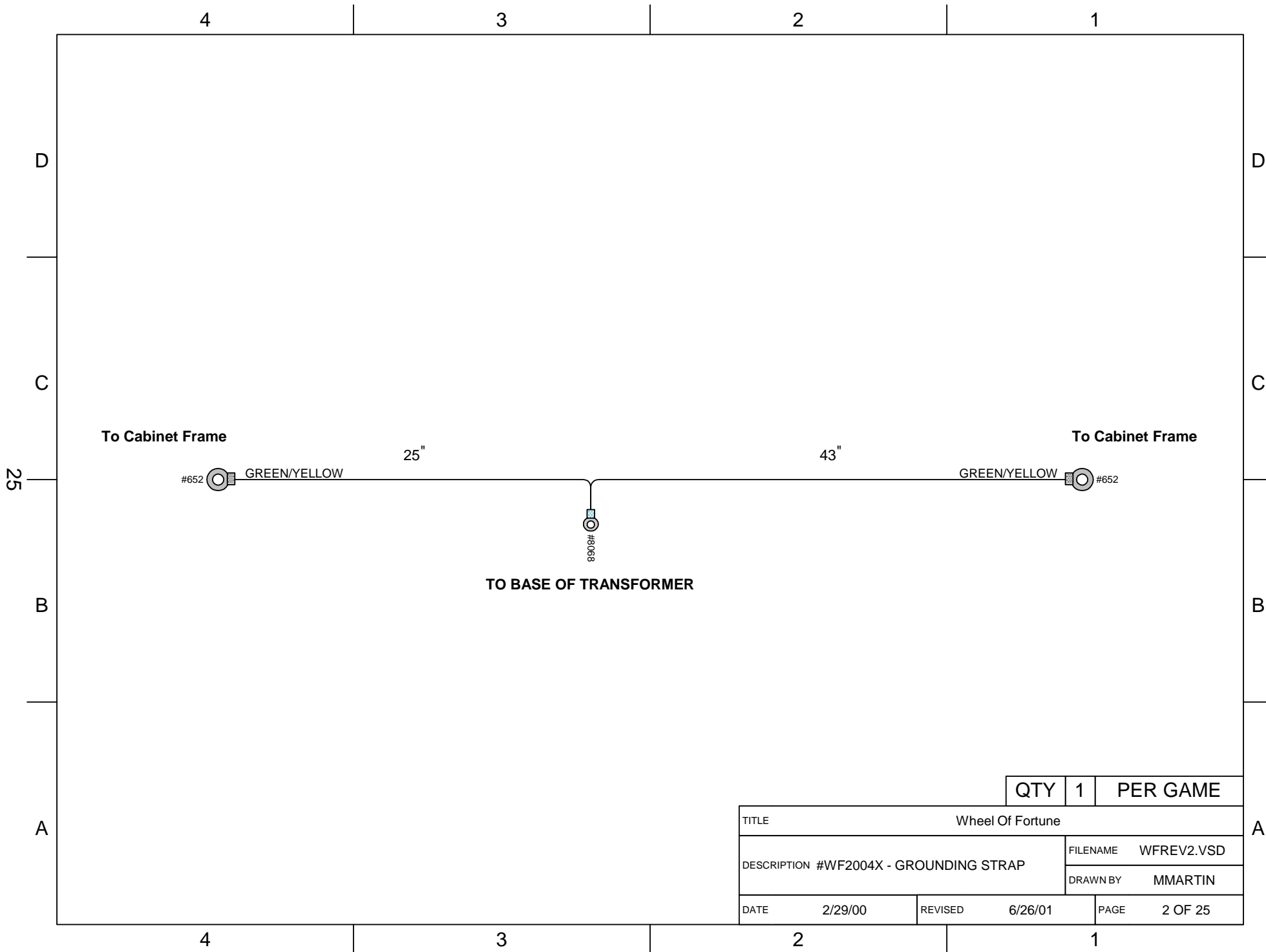

TITLE		Wheel Of Fortune	
DESCRIPTION		#WF2004X - GROUNDING STRAP	
DATE		2/29/00	
REVISED		6/26/01	
PAGE		2 OF 25	
QTY	1	PER GAME	
FILENAME		WFREV2.VSD	
DRAWN BY		MMARTIN	

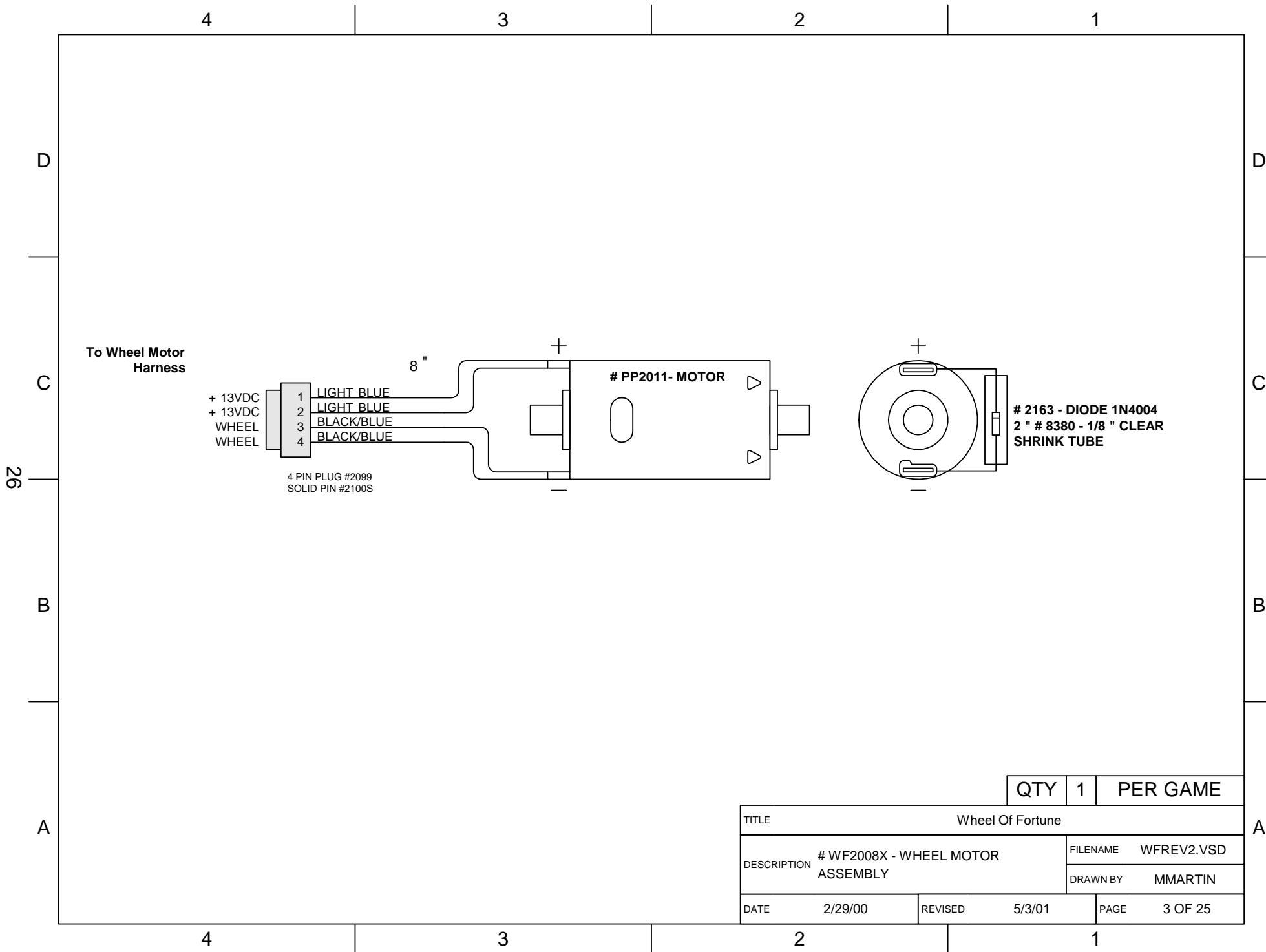

To Wheel Motor
Harness

+ 13VDC
+ 13VDC
WHEEL
WHEEL

1	LIGHT BLUE
2	LIGHT BLUE
3	BLACK/BLUE
4	BLACK/BLUE

4 PIN PLUG #2099
SOLID PIN #2100S

8 "

PP2011- MOTOR

2163 - DIODE 1N4004
2 " # 8380 - 1/8 " CLEAR
SHRINK TUBE

QTY	1	PER GAME
-----	---	----------

TITLE		Wheel Of Fortune	
DESCRIPTION		FILENAME	WFREV2.VSD
		DRAWN BY	MMARTIN
DATE	2/29/00	REVISED	5/3/01
PAGE		3 OF 25	

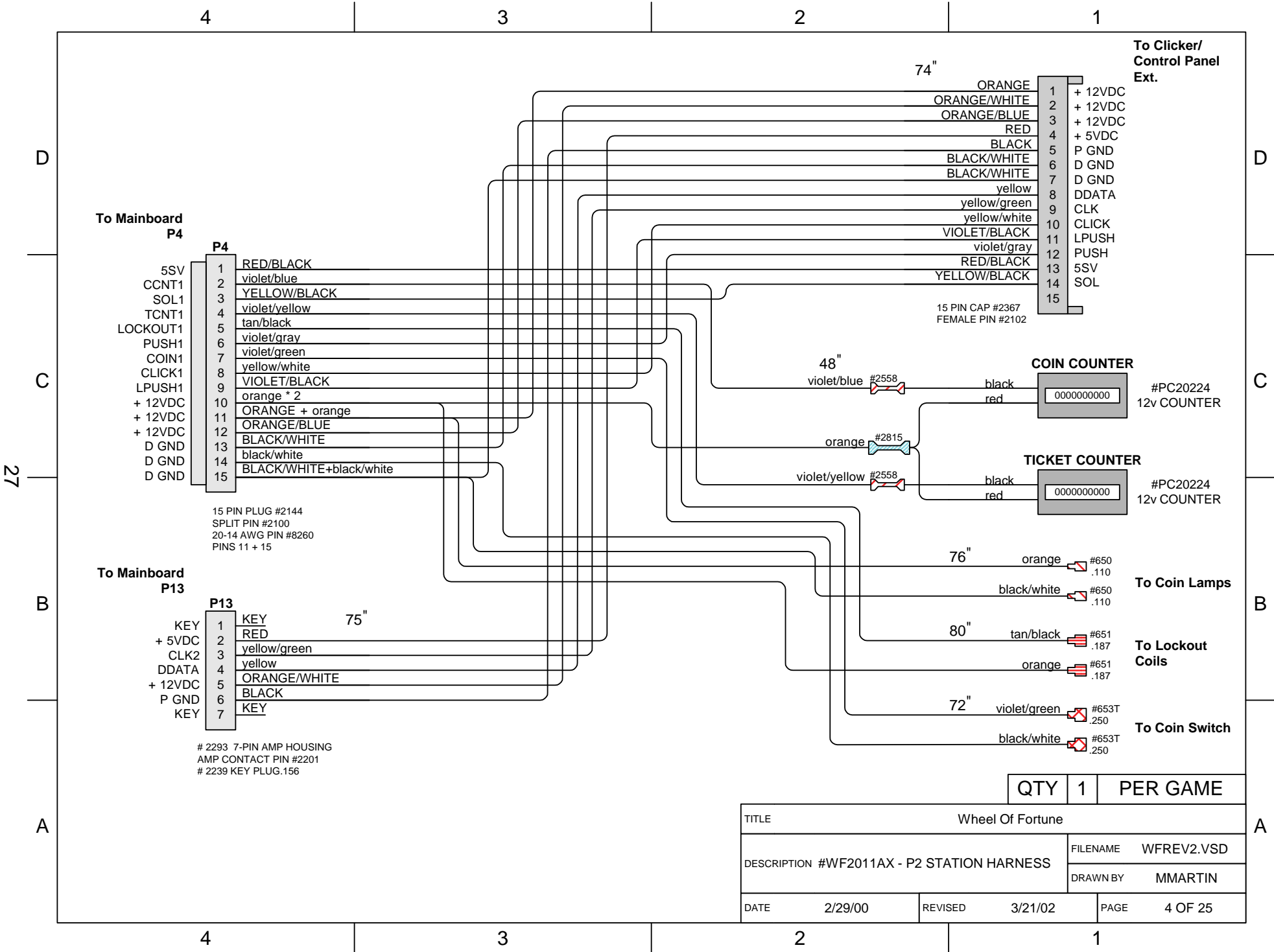

QTY		1	PER GAME		
TITLE Wheel Of Fortune					
DESCRIPTION #WF2011AX - P2 STATION HARNESS			FILENAME	WFREV2.VSD	
			DRAWN BY	MMARTIN	
DATE	2/29/00	REVISED	3/21/02	PAGE	4 OF 25

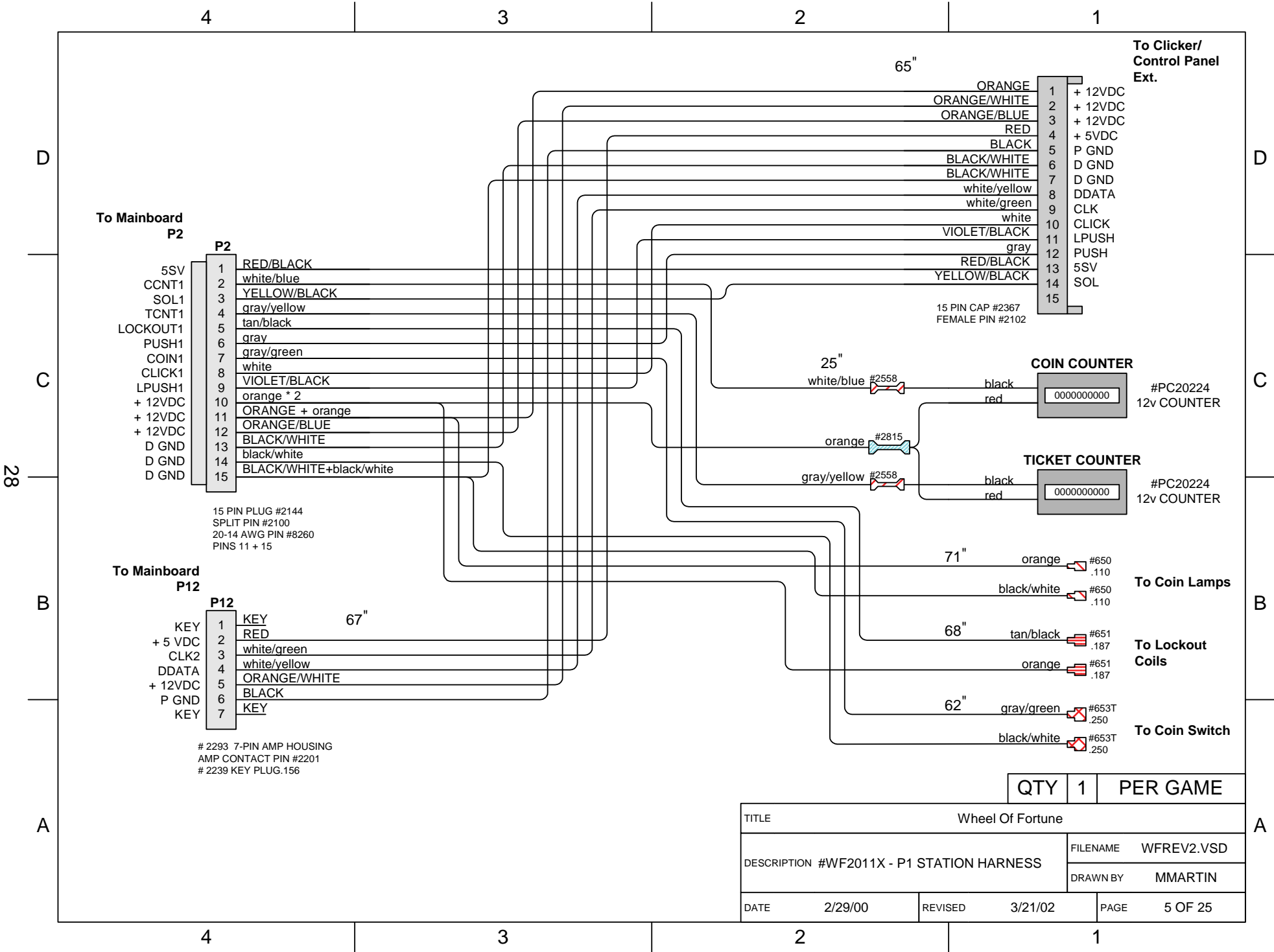

QTY		1	PER GAME	
TITLE Wheel Of Fortune				
DESCRIPTION #WF2011X - P1 STATION HARNESS			FILENAME	WFREV2.VSD
			DRAWN BY	MMARTIN
DATE	2/29/00	REVISED	3/21/02	PAGE 5 OF 25

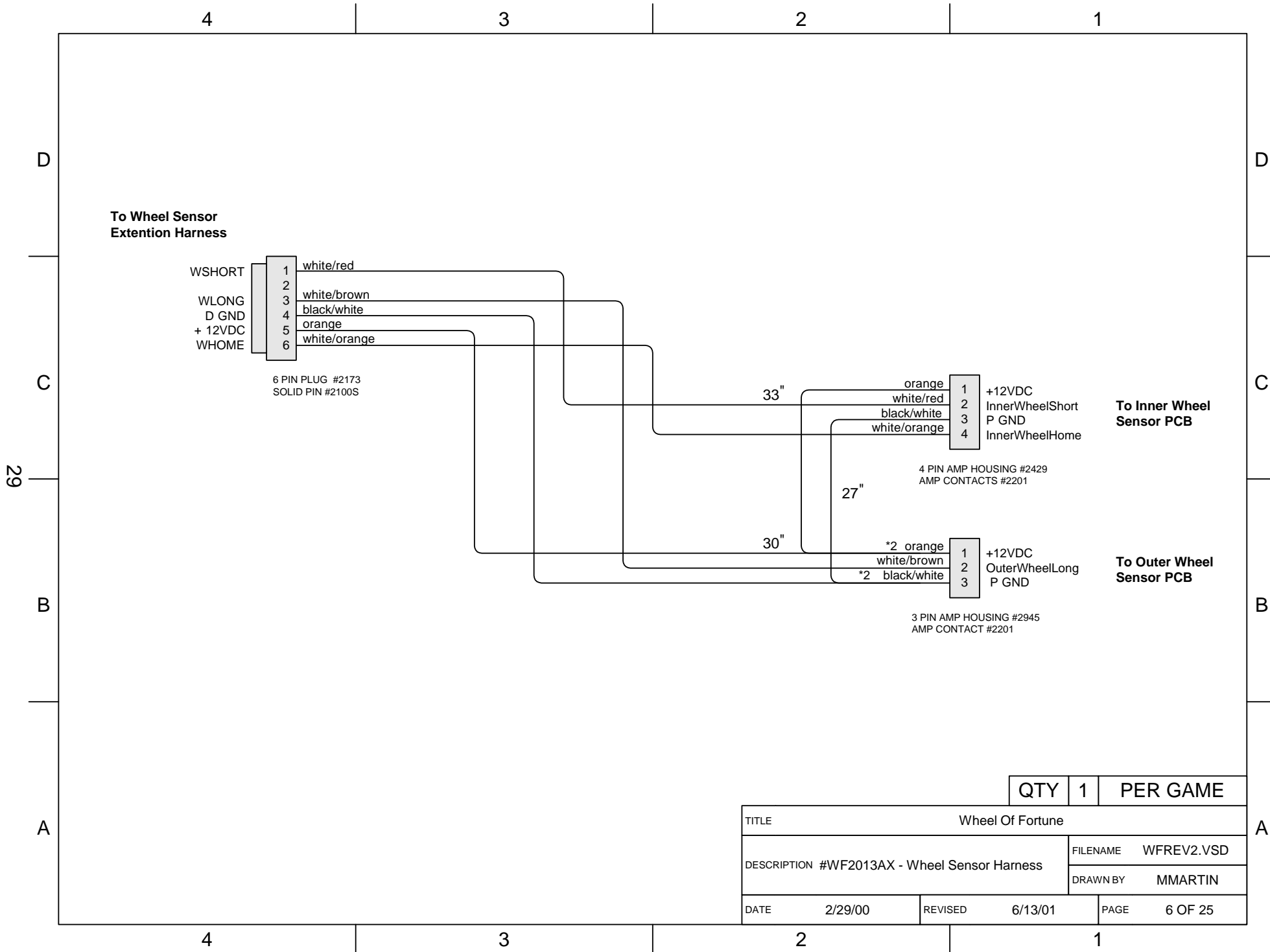

QTY	1	PER GAME
-----	---	----------

TITLE		Wheel Of Fortune	
DESCRIPTION #WF2013AX - Wheel Sensor Harness		FILENAME	WFREV2.VSD
		DRAWN BY	MMARTIN
DATE	2/29/00	REVISED	6/13/01
		PAGE	6 OF 25

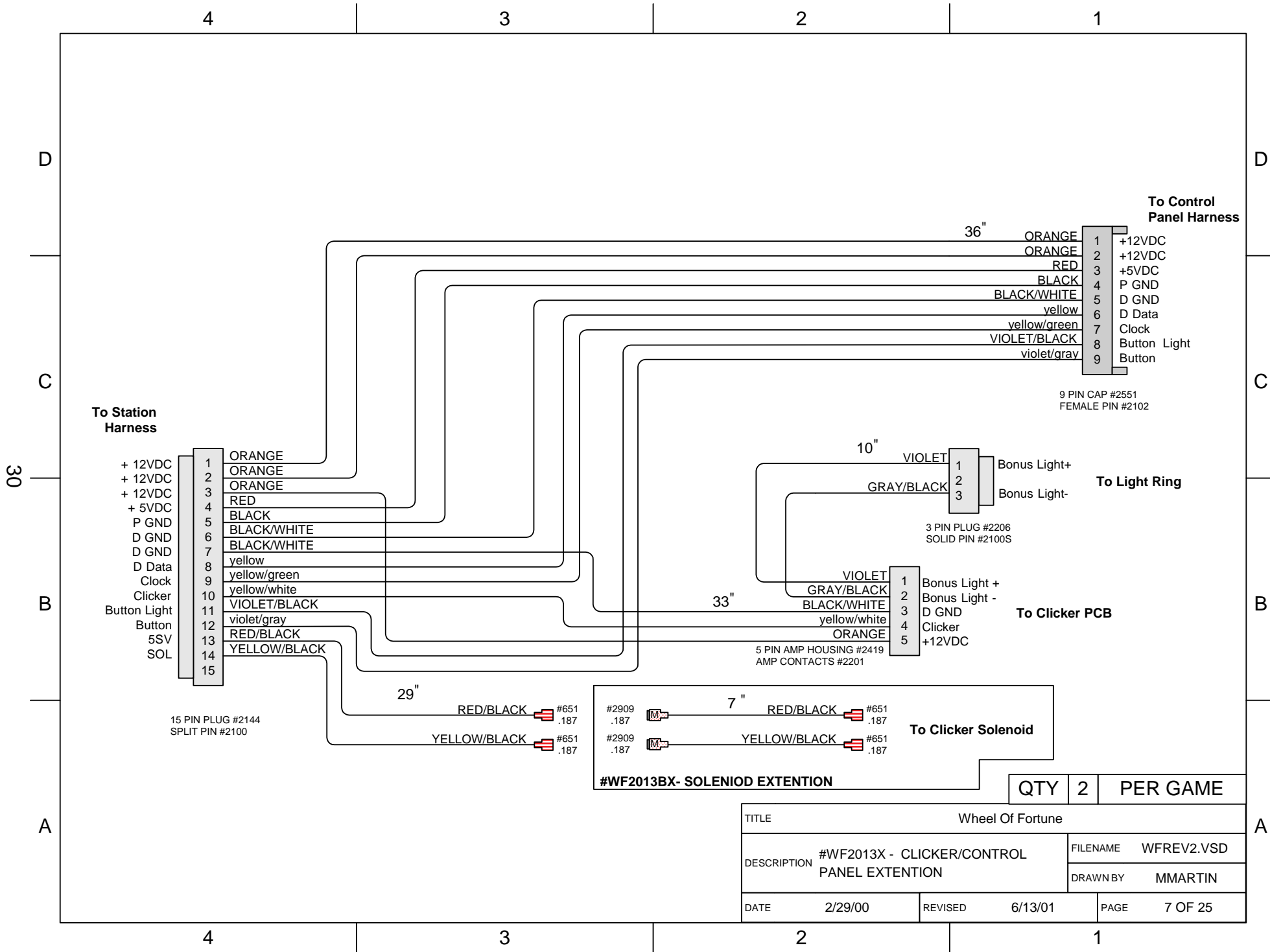

QTY	2	PER GAME
-----	---	----------

TITLE	Wheel Of Fortune		
DESCRIPTION	#WF2013X - CLICKER/CONTROL PANEL EXTENTION	FILENAME	WFREV2.VSD
		DRAWN BY	MMARTIN
DATE	2/29/00	REVISED	6/13/01
		PAGE	7 OF 25

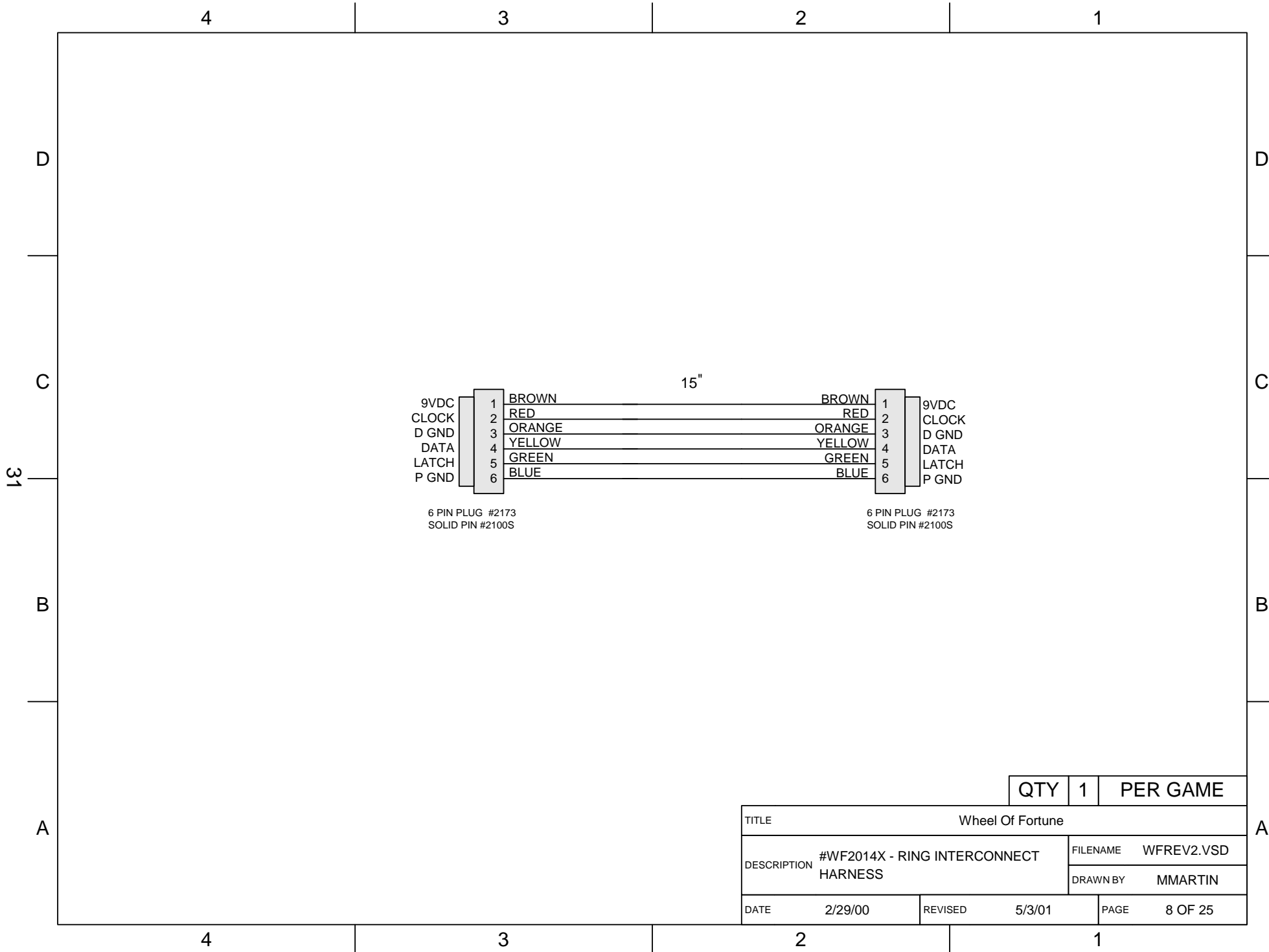

QTY	1	PER GAME
-----	---	----------

TITLE		Wheel Of Fortune			
DESCRIPTION	#WF2014X - RING INTERCONNECT HARNESS		FILENAME	WFREV2.VSD	
			DRAWN BY	MMARTIN	
DATE	2/29/00	REVISED	5/3/01	PAGE	8 OF 25

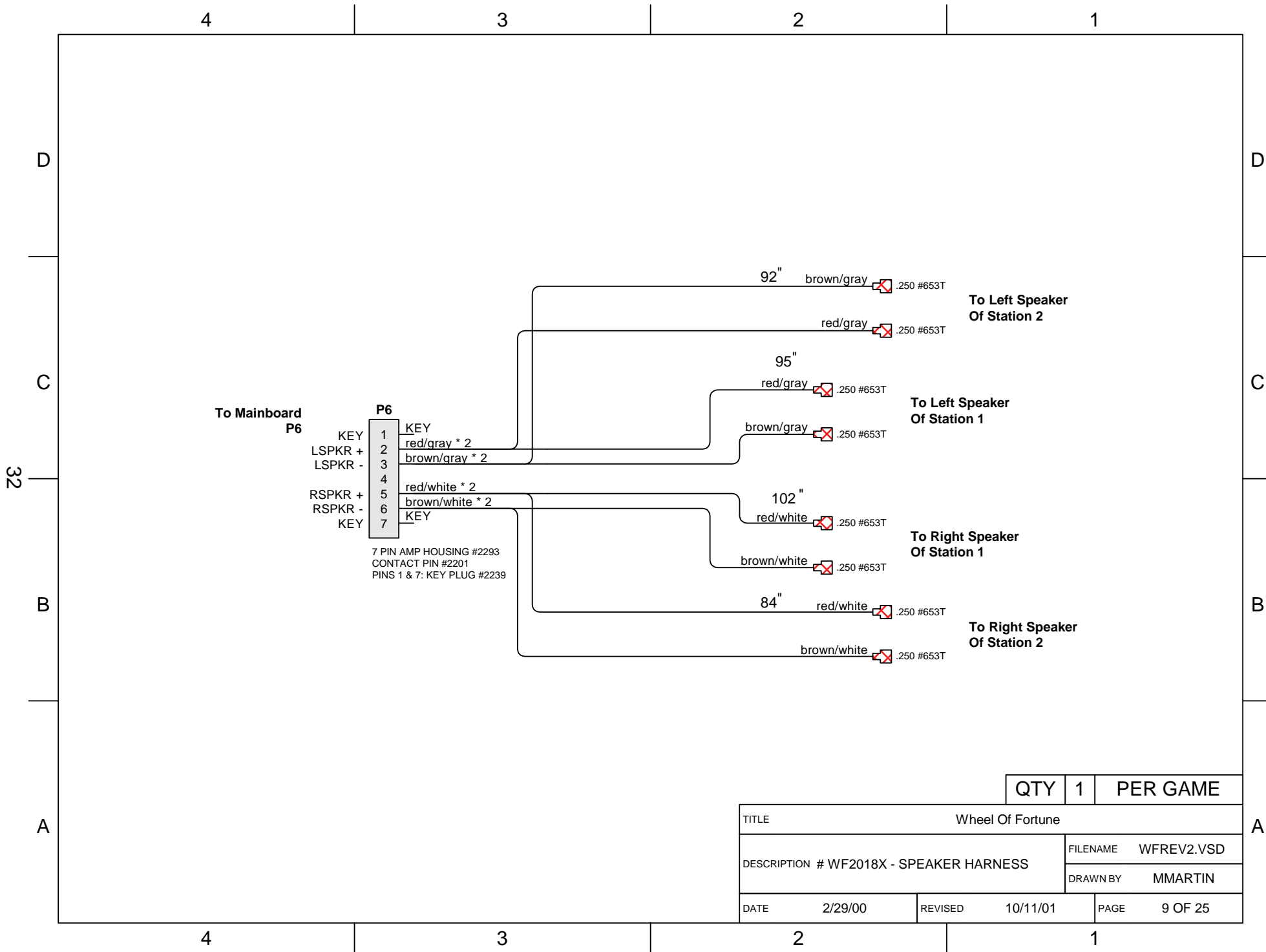

QTY	1	PER GAME
-----	---	----------

TITLE		Wheel Of Fortune	
DESCRIPTION # WF2018X - SPEAKER HARNESS		FILENAME	WFREV2.VSD
		DRAWN BY	MMARTIN
DATE	2/29/00	REVISED	10/11/01
		PAGE	9 OF 25

4

3

2

1

D

D

C

C

33

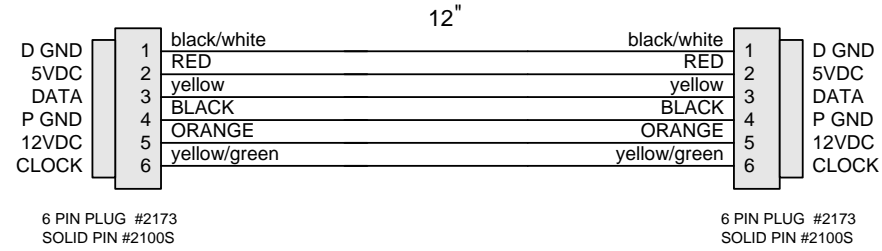

B

B

A

A

4

3

2

1

QTY	2	PER GAME
-----	---	----------

TITLE		Wheel Of Fortune	
DESCRIPTION	#WF2022X - DISPLAY INTERFACE HARNESS		FILENAME WFREV2.VSD
			DRAWN BY MMARTIN
DATE	2/29/00	REVISED	6/13/01
		PAGE	10 OF 25

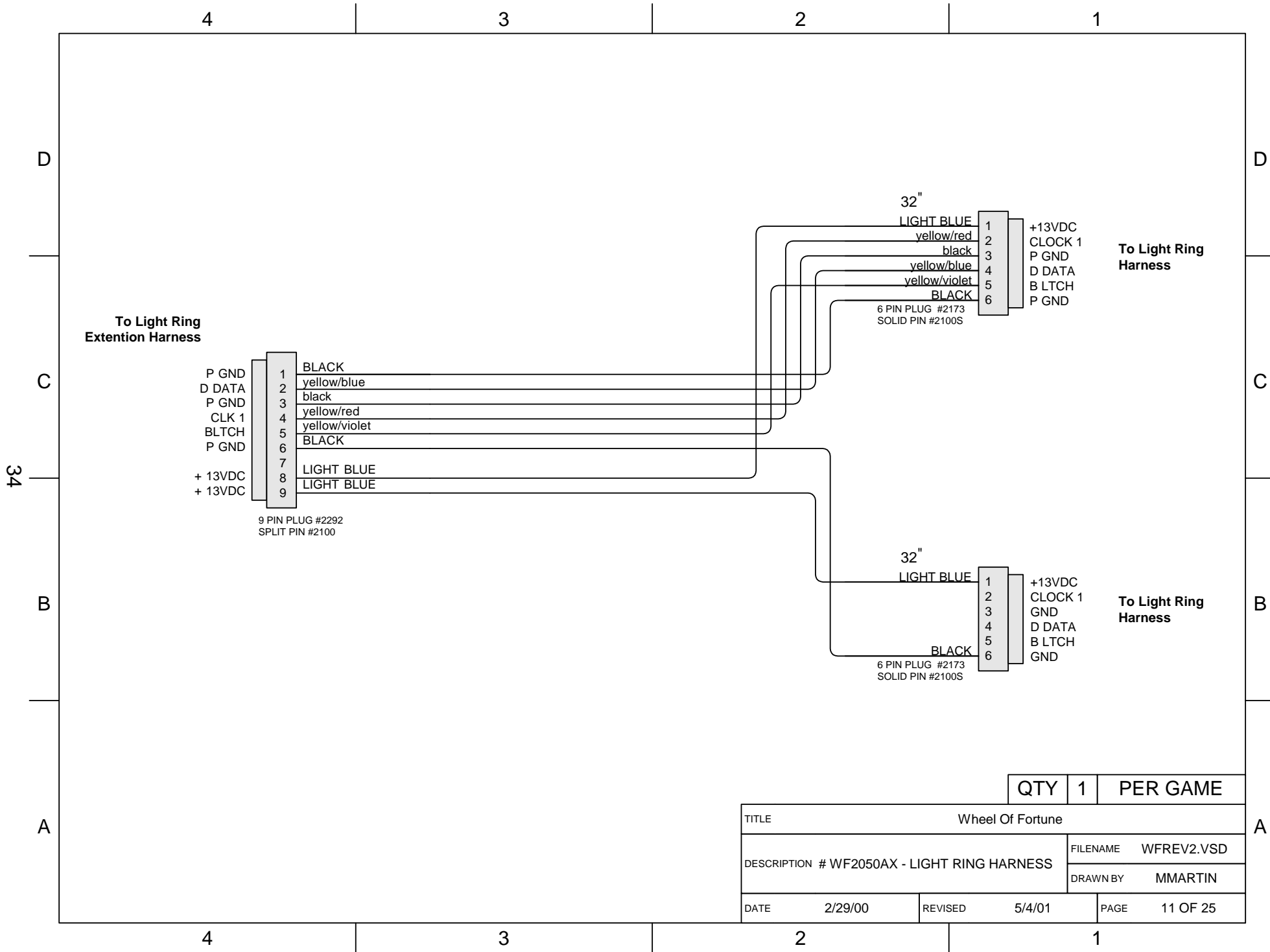

QTY	1	PER GAME
-----	---	----------

TITLE		Wheel Of Fortune	
DESCRIPTION # WF2050AX - LIGHT RING HARNESS		FILENAME	WFREV2.VSD
		DRAWN BY	MMARTIN
DATE	2/29/00	REVISED	5/4/01
		PAGE	11 OF 25

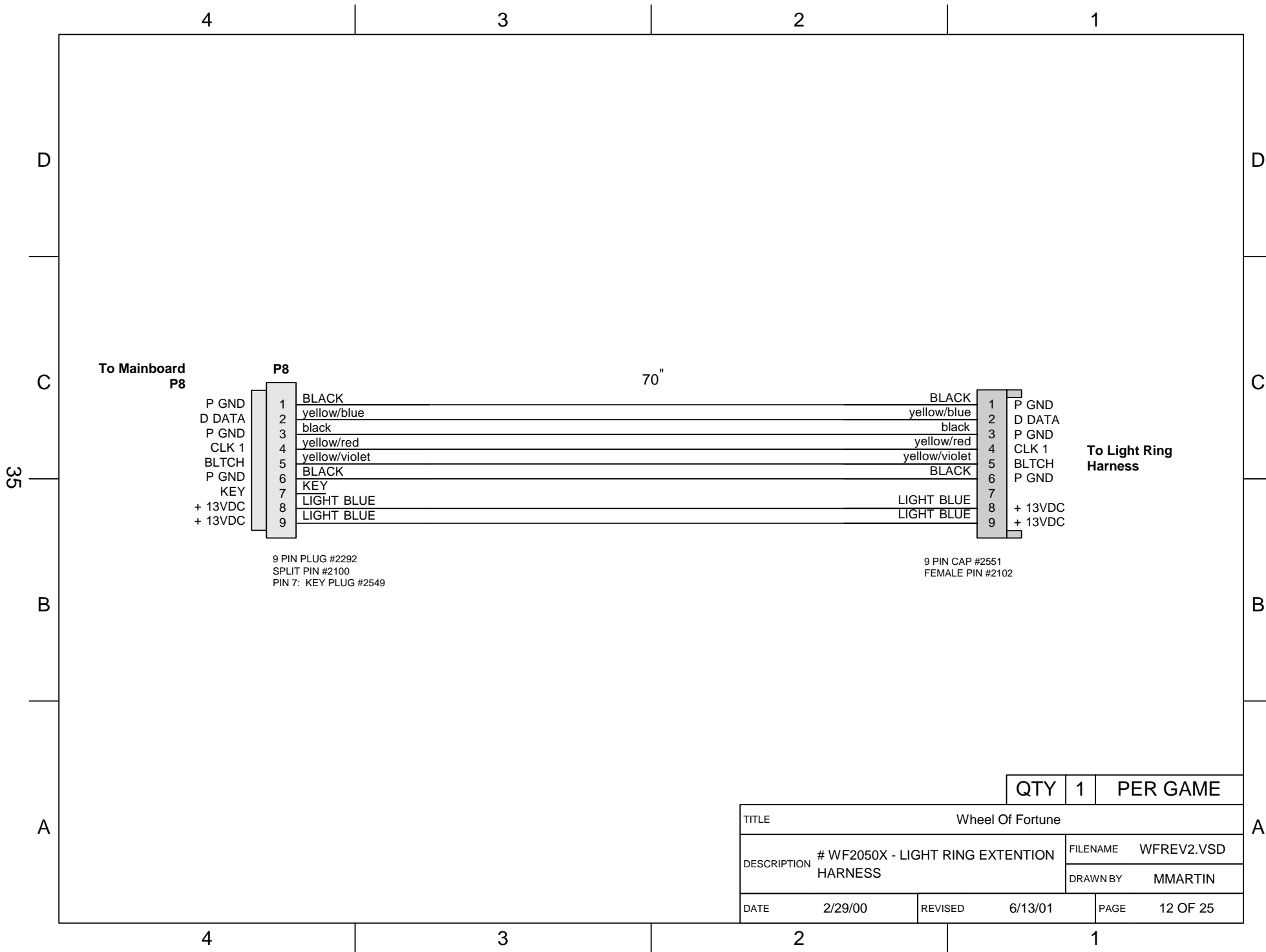

QTY		1	PER GAME	
TITLE Wheel Of Fortune				
DESCRIPTION # WF2050X - LIGHT RING EXTENTION HARNESS			FILENAME	WFREV2.VSD
			DRAWN BY	MMARTIN
DATE	2/29/00	REVISED	6/13/01	PAGE 12 OF 25

4

3

2

1

D

D

C

C

36

B

B

A

A

To Mainboard
P7

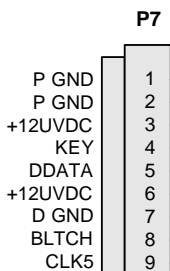

9 PIN PLUG #2292
SPLIT PIN #2100
PIN 4: KEY PLUG #2549

* Start Spiral Wrap (# 8069) 34" From 9-Pin Plug

Cut Spiral Wrap 26" To Cover 18" Of Harness

92"

8 PIN HOUSING #2405
WITH AMP CONTACT #2201



QTY 1 PER GAME

TITLE		Wheel Of Fortune	
DESCRIPTION		FILENAME	WFREV2.VSD
		DRAWN BY	MMARTIN
DATE	2/29/00	REVISED	6/13/01
		PAGE	13 OF 25

4

3

2

1

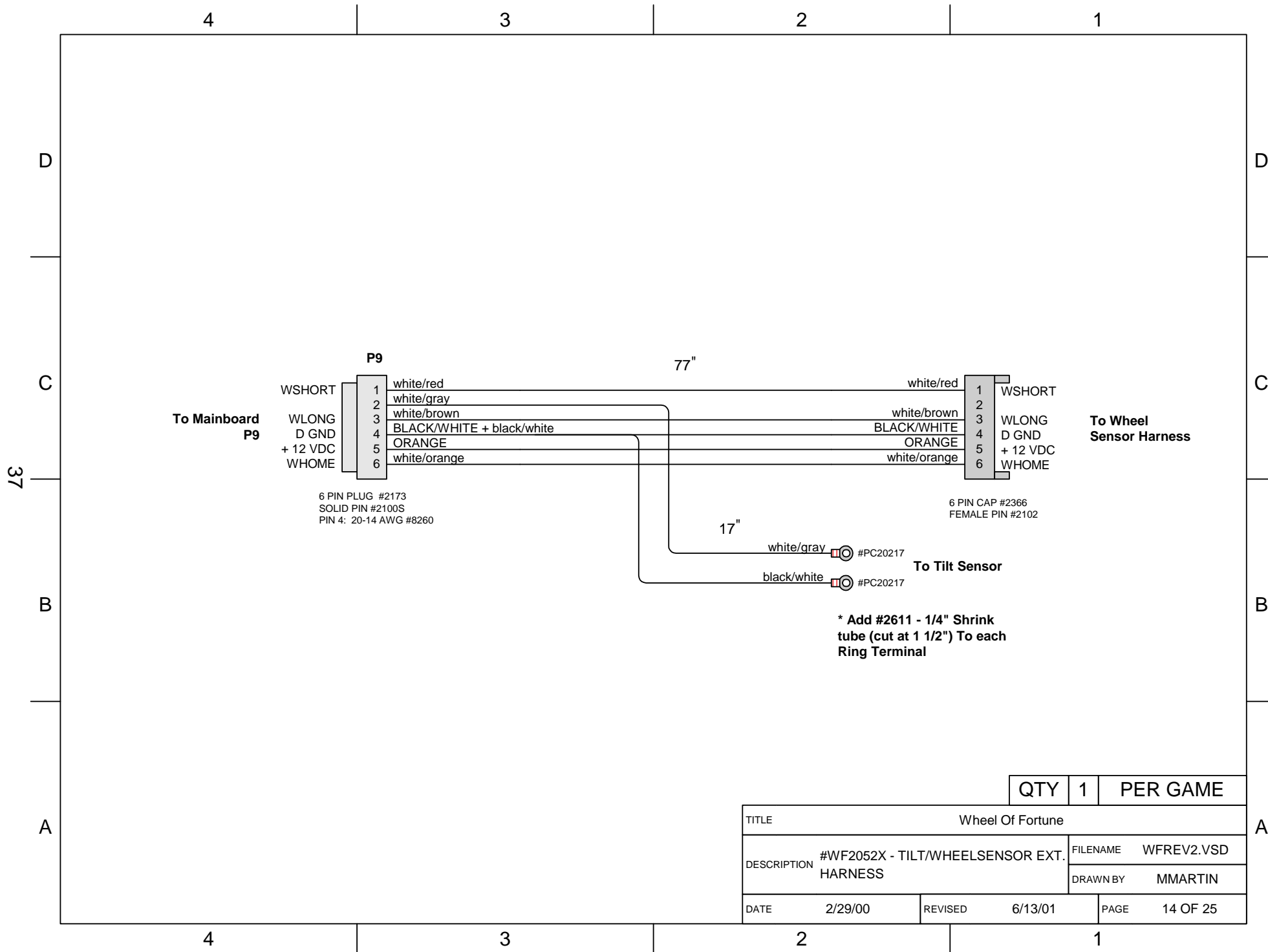

To Mainboard
P9

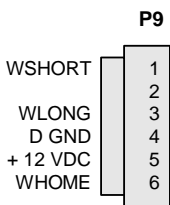

6 PIN PLUG #2173
SOLID PIN #2100S
PIN 4: 20-14 AWG #8260

77"

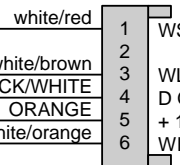

6 PIN CAP #2366
FEMALE PIN #2102

To Wheel
Sensor Harness

17"

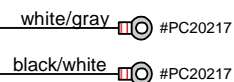

To Tilt Sensor

* Add #2611 - 1/4" Shrink
tube (cut at 1 1/2") To each
Ring Terminal

QTY	1	PER GAME
-----	---	----------

TITLE		Wheel Of Fortune	
DESCRIPTION	#WF2052X - TILT/WHEELSENSOR EXT. HARNESS		FILENAME WFREV2.VSD
			DRAWN BY MMARTIN
DATE	2/29/00	REVISED	6/13/01
		PAGE	14 OF 25

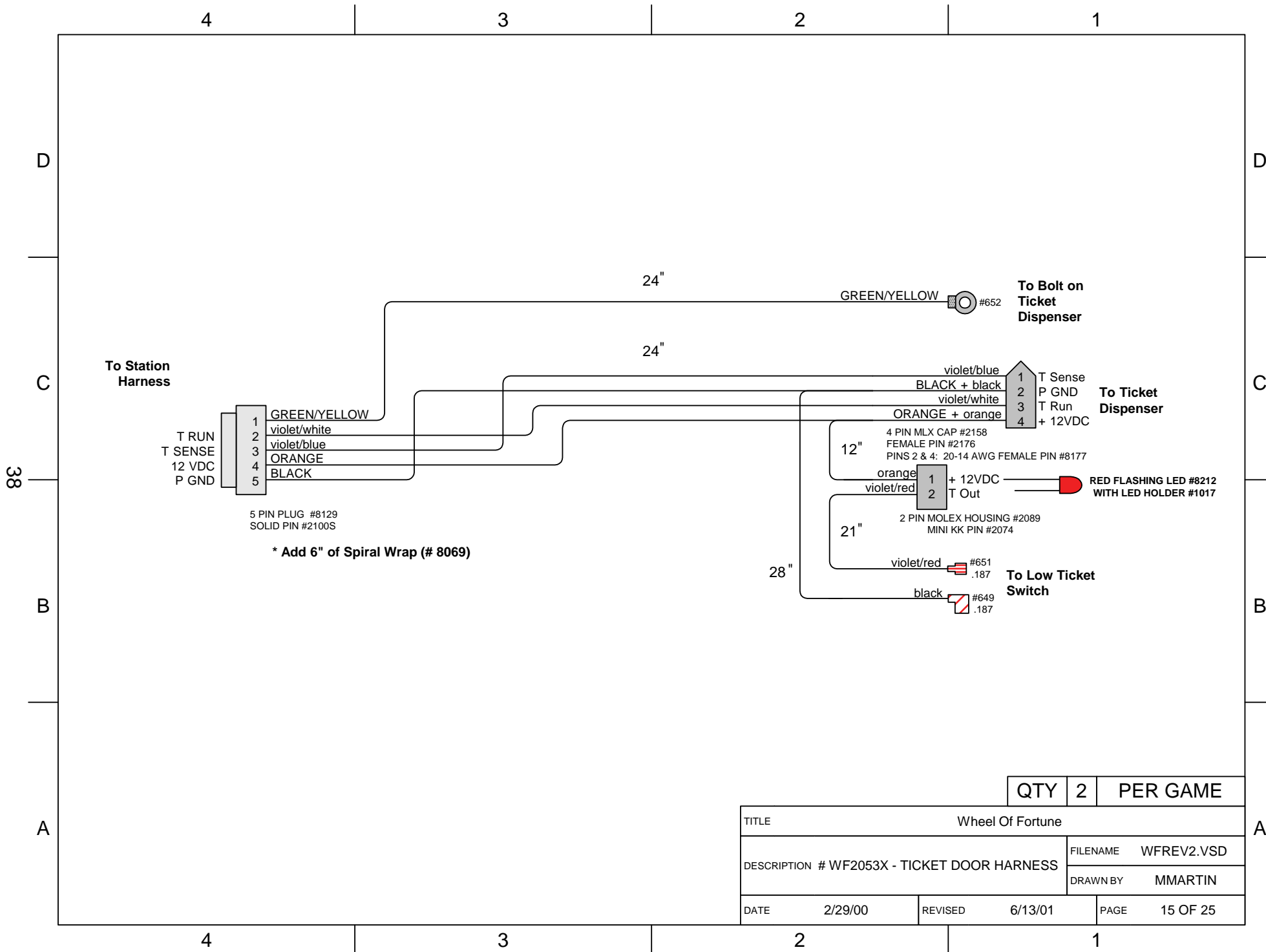

* Add 6" of Spiral Wrap (# 8069)

QTY	2	PER GAME
-----	---	----------

TITLE		Wheel Of Fortune	
DESCRIPTION # WF2053X - TICKET DOOR HARNESS		FILENAME	WFREV2.VSD
		DRAWN BY	MMARTIN
DATE	2/29/00	REVISED	6/13/01
PAGE	15 OF 25		

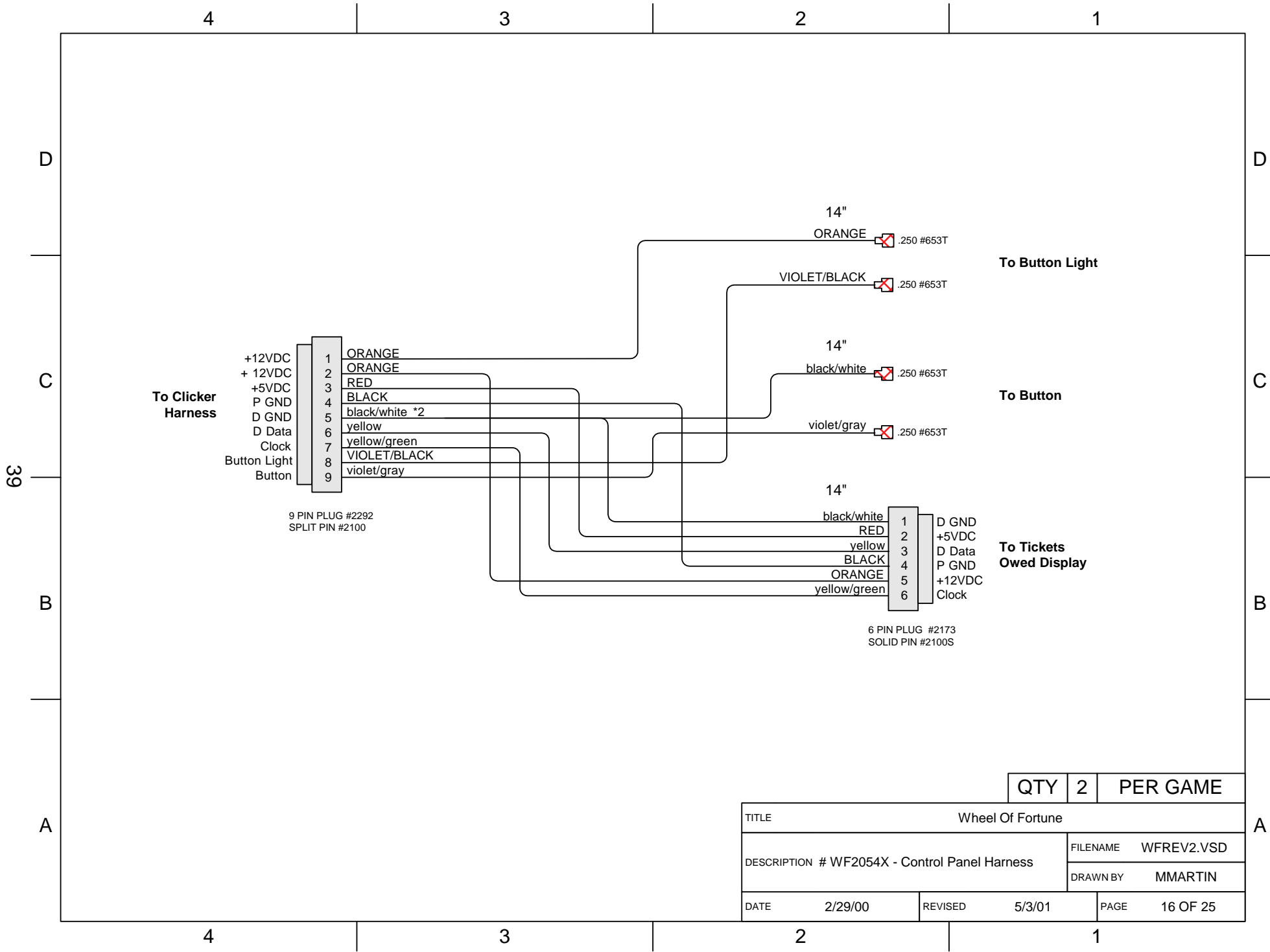

QTY	2	PER GAME
-----	---	----------

TITLE		Wheel Of Fortune	
DESCRIPTION # WF2054X - Control Panel Harness		FILENAME	WFREV2.VSD
		DRAWN BY	MMARTIN
DATE	2/29/00	REVISED	5/3/01
		PAGE	16 OF 25

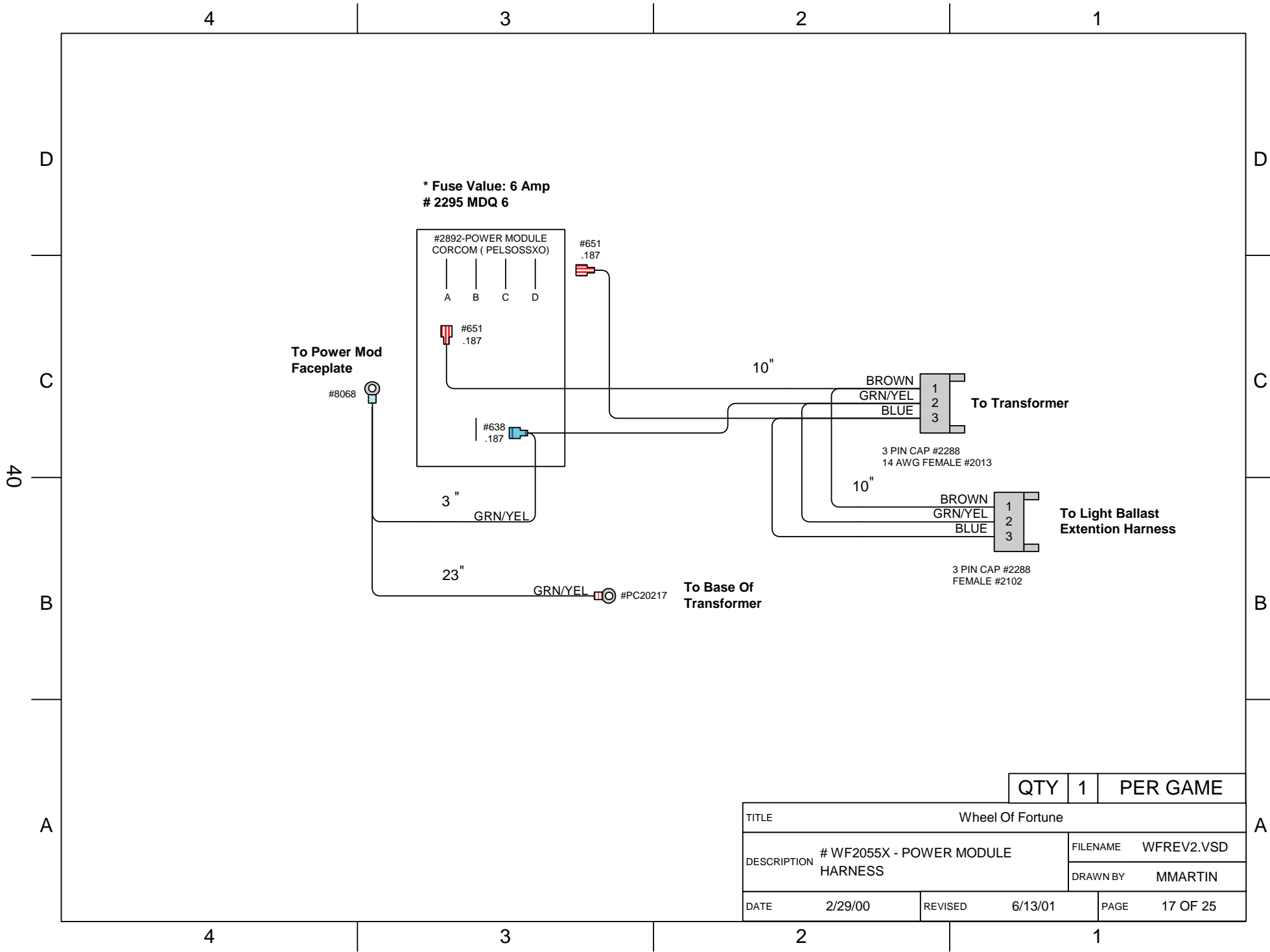

QTY	1	PER GAME
-----	---	----------

TITLE		Wheel Of Fortune	
DESCRIPTION	# WF2055X - POWER MODULE HARNESS		FILENAME WFREV2.VSD
			DRAWN BY MMARTIN
DATE	2/29/00	REVISED	6/13/01
		PAGE	17 OF 25

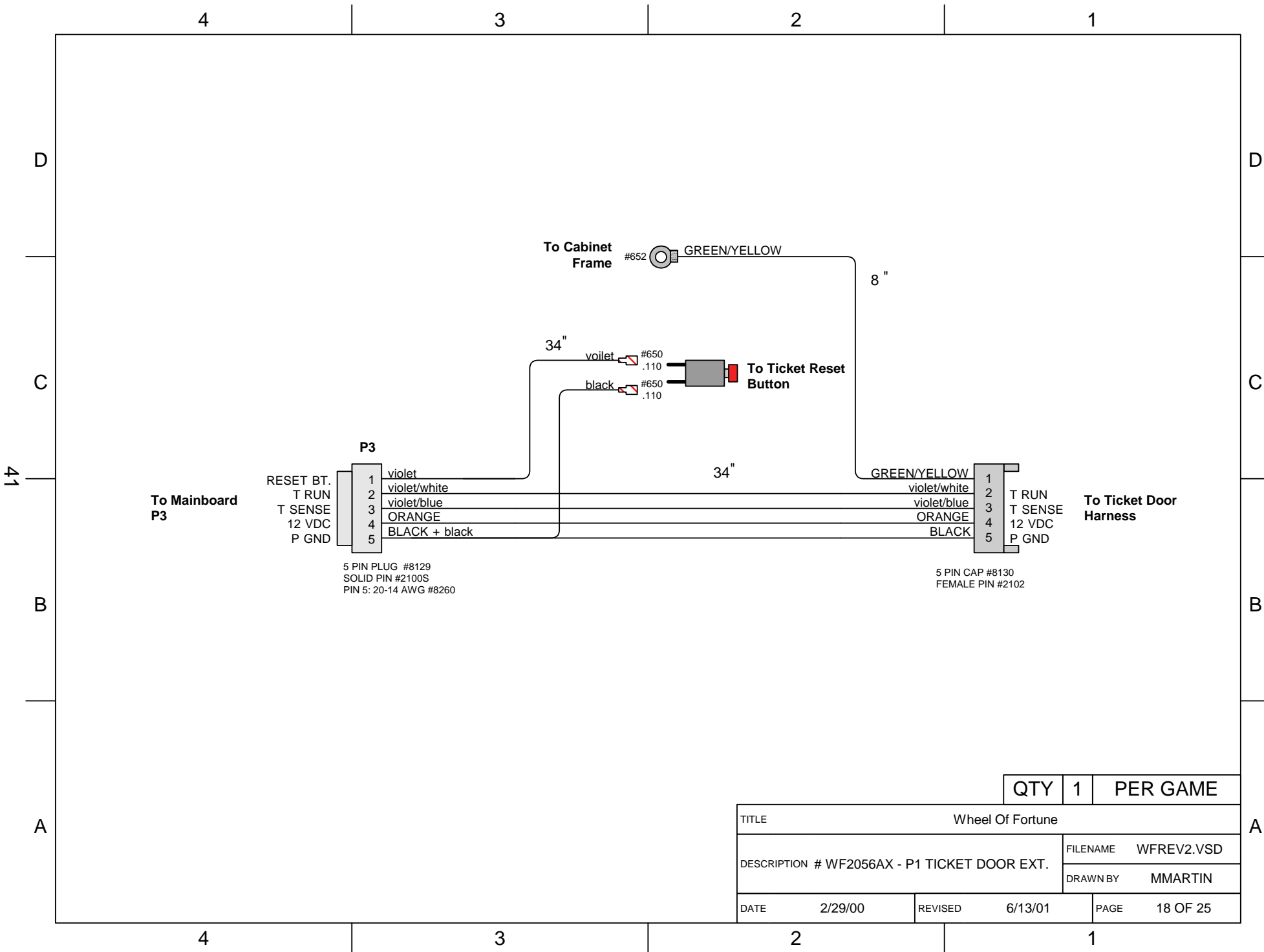

To Mainboard
P3

RESET BT.
T RUN
T SENSE
12 VDC
P GND

P3

1 violet
2 violet/white
3 violet/blue
4 ORANGE
5 BLACK + black

5 PIN PLUG #8129
SOLID PIN #2100S
PIN 5: 20-14 AWG #8260

To Cabinet
Frame



#652 GREEN/YELLOW

8"

34"

violet #650 .110
black #650 .110



To Ticket Reset
Button

34"

GREEN/YELLOW
violet/white
violet/blue
ORANGE
BLACK

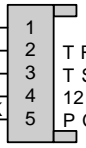

1
2 T RUN
3 T SENSE
4 12 VDC
5 P GND

To Ticket Door
Harness

5 PIN CAP #8130
FEMALE PIN #2102

QTY	1	PER GAME
-----	---	----------

TITLE		Wheel Of Fortune	
DESCRIPTION # WF2056AX - P1 TICKET DOOR EXT.		FILENAME	WFREV2.VSD
		DRAWN BY	MMARTIN
DATE	2/29/00	REVISED	6/13/01
		PAGE	18 OF 25

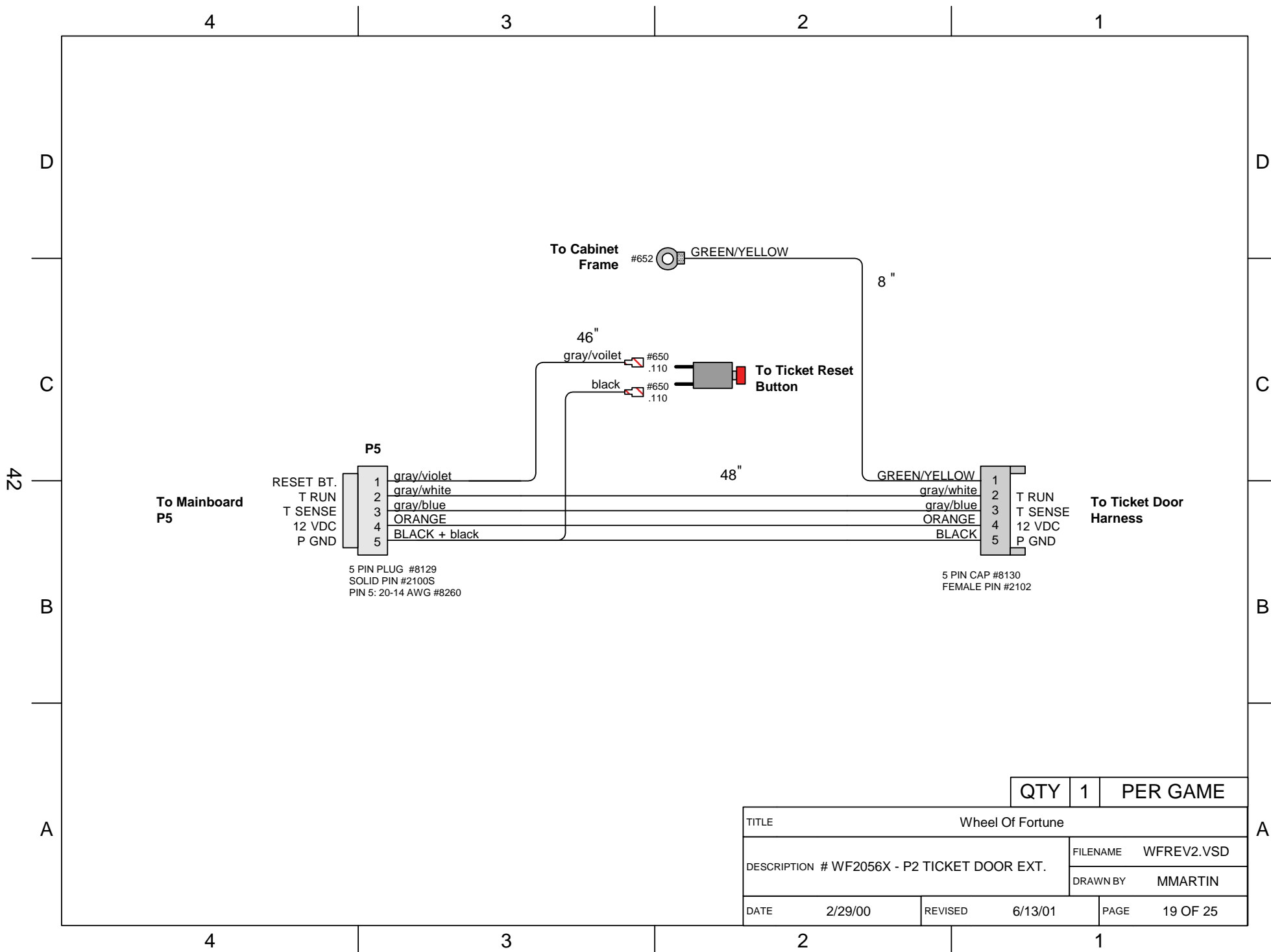

QTY	1	PER GAME
-----	---	----------

TITLE		Wheel Of Fortune	
DESCRIPTION # WF2056X - P2 TICKET DOOR EXT.		FILENAME	WFREV2.VSD
		DRAWN BY	MMARTIN
DATE	2/29/00	REVISED	6/13/01
		PAGE	19 OF 25

4

3

2

1

D

D

C

C

43

To Wheel Motor
Extention Harness

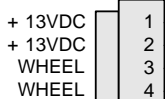

4 PIN PLUG #2099
SOLID PIN #2100S

1 LIGHT BLUE
2 LIGHT BLUE
3 BLACK/BLUE
4 BLACK/BLUE

27"

LIGHT BLUE
LIGHT BLUE
BLACK/BLUE
BLACK/BLUE



4 PIN CAP #2101
FEMALE PIN #2102

1 + 13VDC
2 + 13VDC
3 WHEEL
4 WHEEL

To Wheel Motor
Assembly

B

B

A

A

4

3

2

1

QTY	1	PER GAME
-----	---	----------

TITLE		Wheel Of Fortune	
DESCRIPTION	# WF2057AX - WHEEL MOTOR HARNESS		FILENAME WFREV2.VSD
			DRAWN BY MMARTIN
DATE	2/29/00	REVISED	5/3/01
		PAGE	20 OF 25

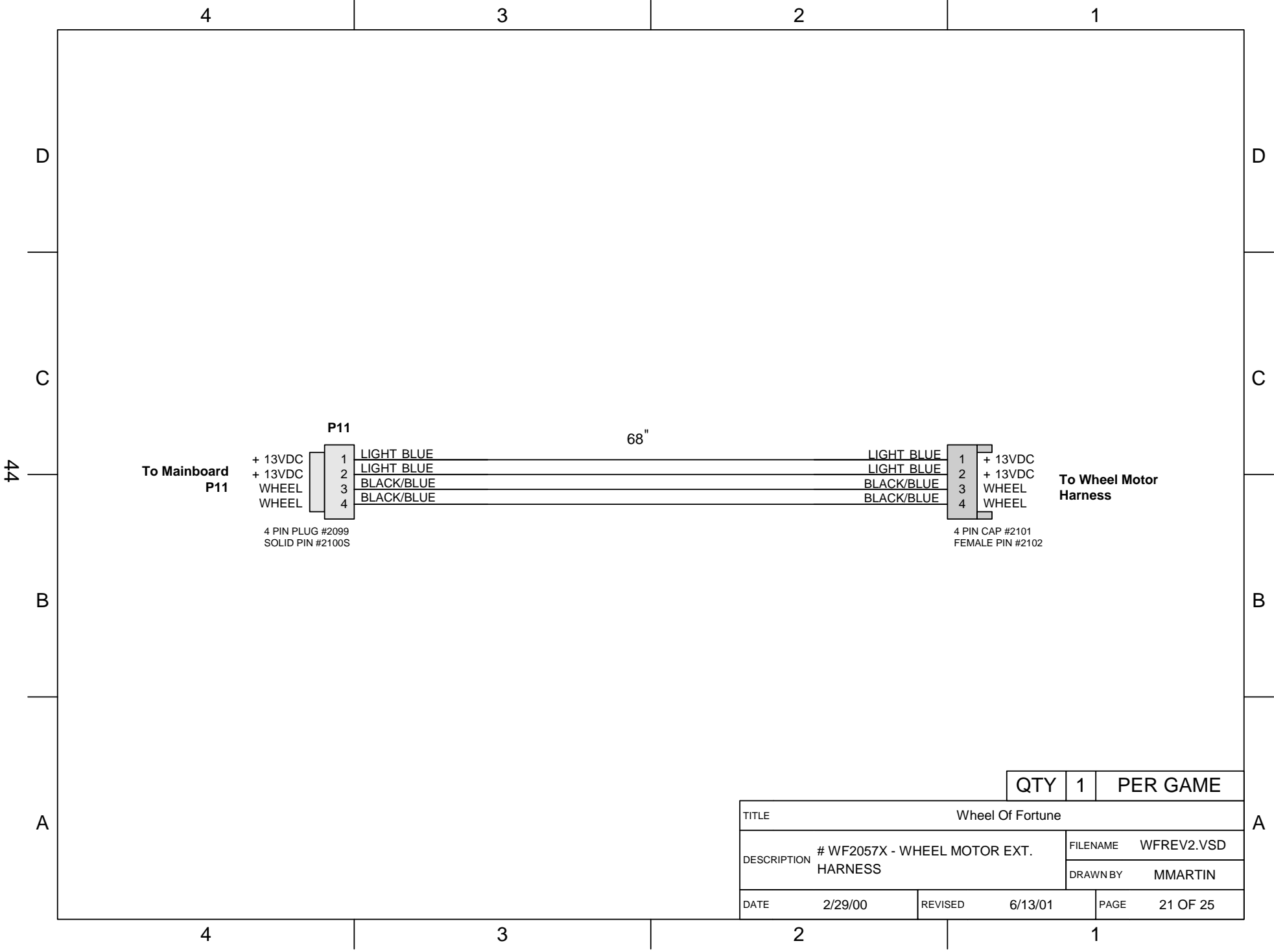

QTY	1	PER GAME
-----	---	----------

TITLE		Wheel Of Fortune	
DESCRIPTION	# WF2057X - WHEEL MOTOR EXT. HARNESS		FILENAME WFREV2.VSD
			DRAWNBY MMARTIN
DATE	2/29/00	REVISED	6/13/01
		PAGE	21 OF 25

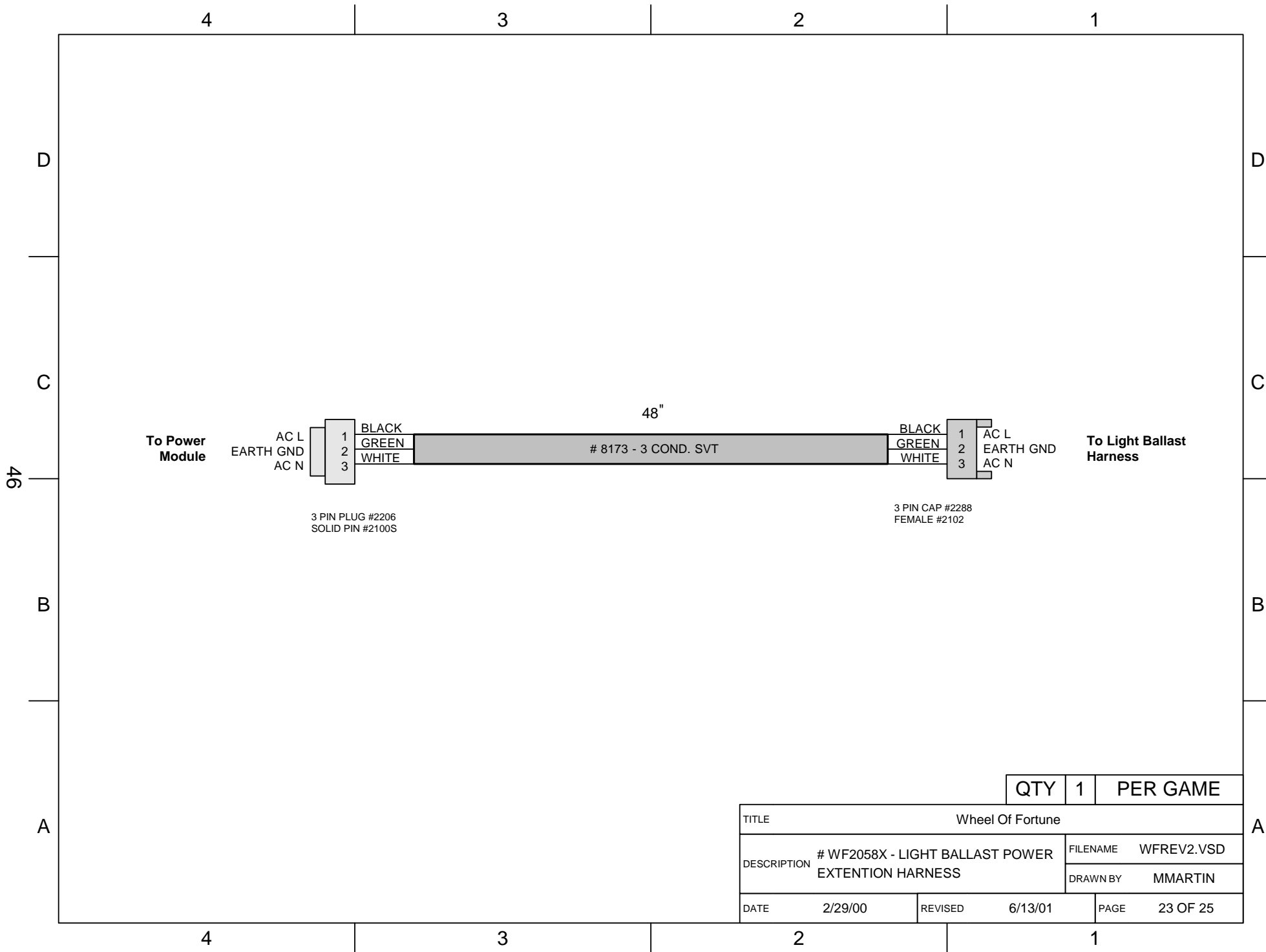

3 PIN PLUG #2206
SOLID PIN #2100S

3 PIN CAP #2288
FEMALE #2102

QTY	1	PER GAME
-----	---	----------

TITLE		Wheel Of Fortune	
DESCRIPTION		FILENAME	WFREV2.VSD
		DRAWN BY	MMARTIN
DATE	2/29/00	REVISED	6/13/01
		PAGE	23 OF 25

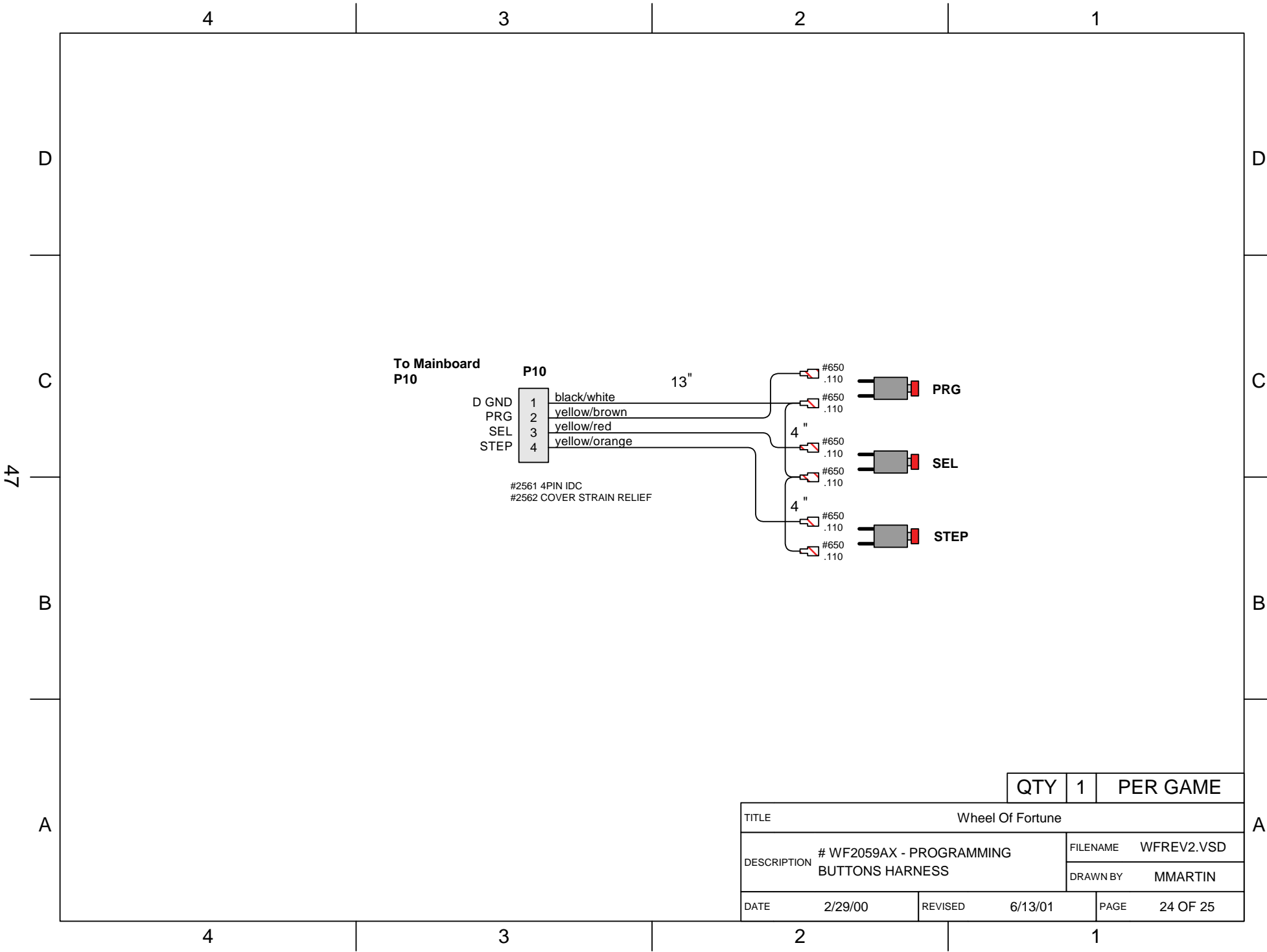

QTY	1	PER GAME
-----	---	----------

TITLE		Wheel Of Fortune	
DESCRIPTION	# WF2059AX - PROGRAMMING BUTTONS HARNESS		FILENAME WFREV2.VSD
			DRAWN BY MMARTIN
DATE	2/29/00	REVISED	6/13/01
		PAGE	24 OF 25

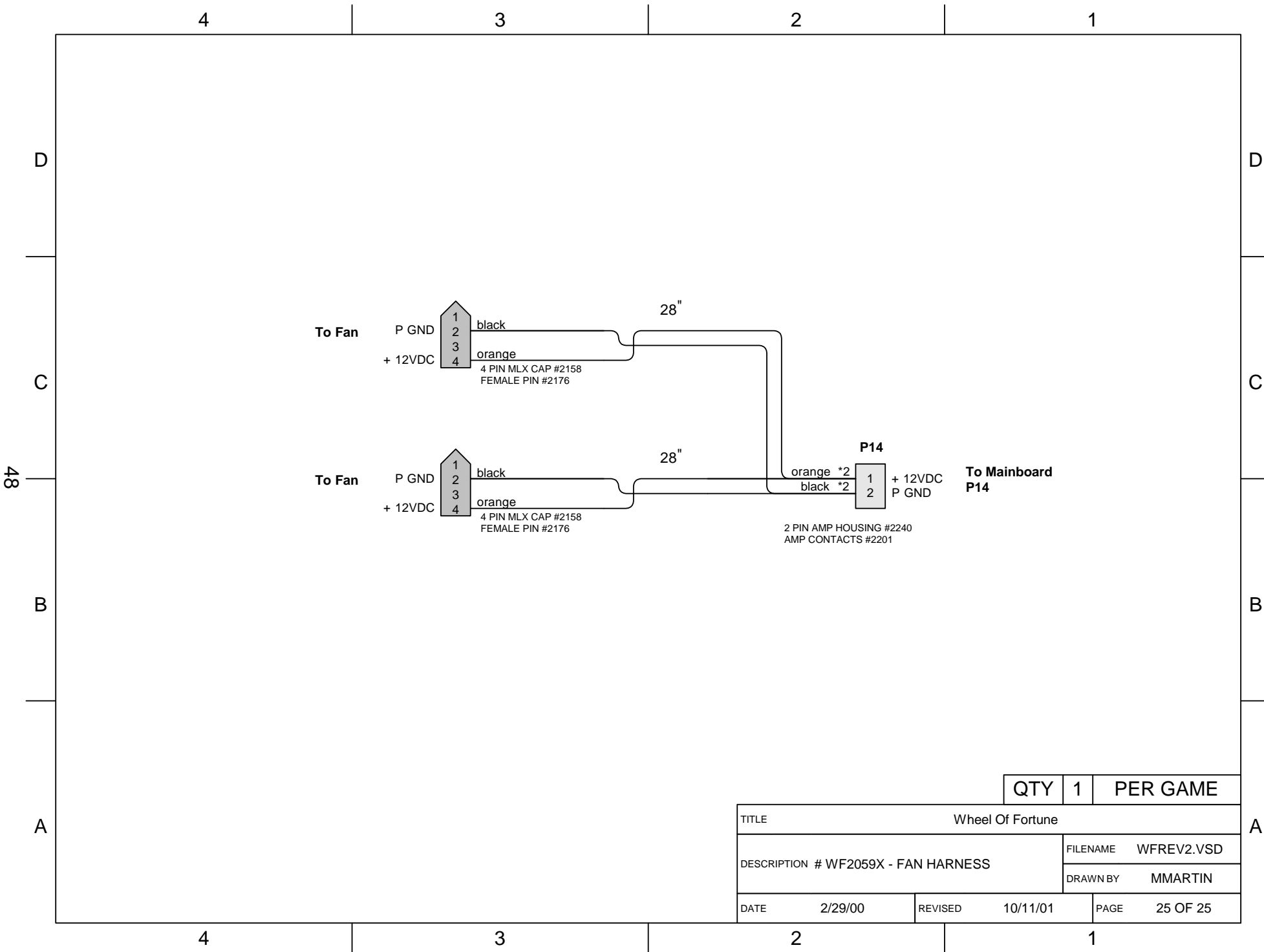

QTY	1	PER GAME
-----	---	----------

TITLE		Wheel Of Fortune	
DESCRIPTION # WF2059X - FAN HARNESS		FILENAME	WFREV2.VSD
		DRAWN BY	MMARTIN
DATE	2/29/00	REVISED	10/11/01
		PAGE	25 OF 25

ITEM NO.	PART NUMBER	DESCRIPTION	QTY.
1	WHEEL	WHEEL	1
2	WF1052	PIN	1
3	WF4002	O-RING	2
4	6729	10-24 NYLOCK LOW PROFILE	1
5	6728	WASHER	2

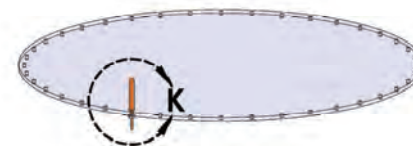
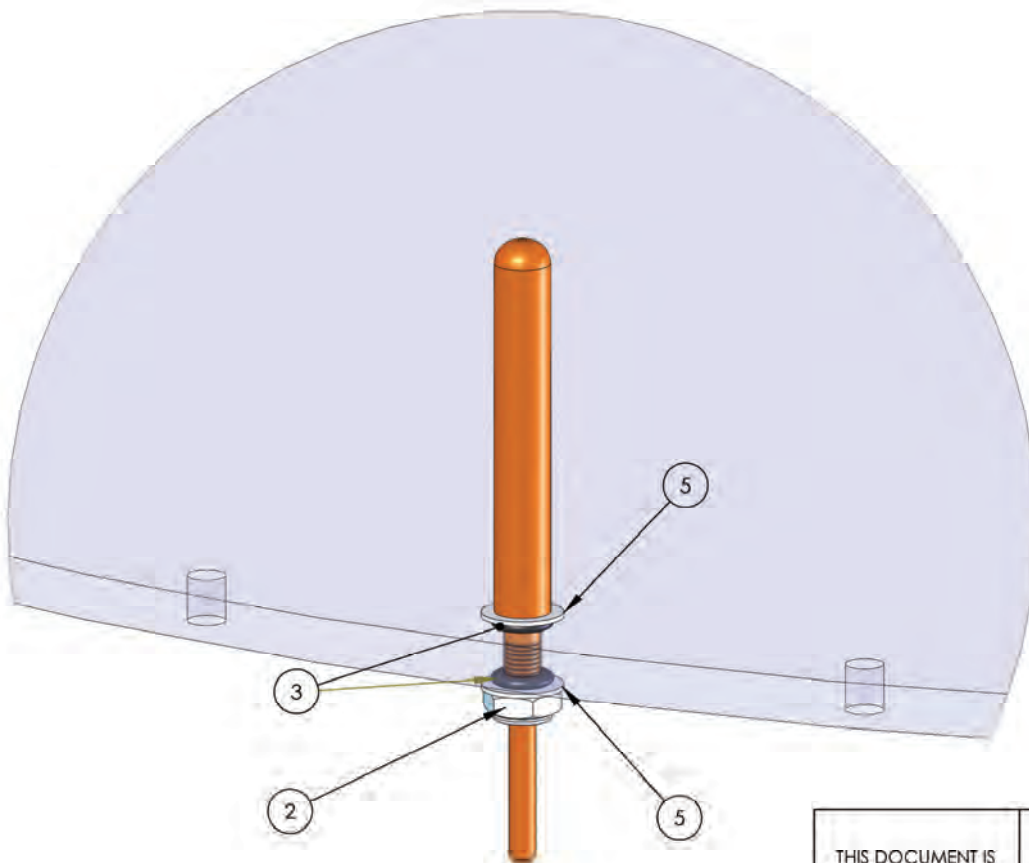

NOTE:

TIGHTEN THE NUT UNTIL THE THREAD OF THE PIN CAN JUST BE SEEN EMERGING FROM THE LOCKNUT

NOTES:

1. DEBURR ALL SHARP EDGES AND BREAK ALL SHARP CORNERS.
2. ALL BENDS MIN. RADIUS UNLESS SPECIFIED

THIS DOCUMENT IS PROPERTY OF I.C.E. AND IS CONSIDERED PROPRIETARY AND CONFIDENTIAL. NO REPRODUCTION OR DISCLOSURE OF THIS DOCUMENT SHALL BE MADE AND THIS DOCUMENT SHALL BE RETURNED INTACT UPON REQUEST.	REV. DESCRIPTION ECN# BY DATE
	
DEBURR EDGES: NO TOOL MARKS ON VISIBLE AREAS INSIDE RADIUS: ROUTED CORNERS 1/4" RAD THREE PLACE DECIMALS ±0.015 TWO PLACE DECIMALS ±0.030 ONE PLACE DECIMALS ±0.060 ANGULAR - SHEET METAL BENDS ± 2°	TITLE: PIN ASSEMBLY PART NO.: WWUPD3277X
FINISH:	DESIGN: DRAWN: JTL JTL SCALE: 1:12 TO 'A' SIZE
MATERIAL:	DWG. NO.: WWUPD3277X REV: 1 1 of 1

Weight: Material not specified



Contacts at SEGA



Machine Sales

Telephone: +44 (0) 208 391 8090

Fax: +44 (0) 208 391 8099

www.sega-amusements.co.uk

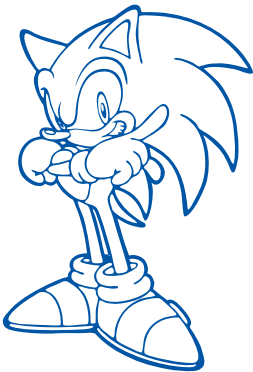

SEGA Spares

Telephone: +44 (0) 208 391 8060

Fax: +44 (0) 208 391 8096

www.segatotalsolutions.com

Customer Services

Telephone: +44 (0) 208 391 8065

Fax: +44 (0) 208 391 8096